

Valves

1-1/2" Stainless Steel Pressure Regulator

Series S20517

Features

- ▶ Original Shear-Seal® technology
- ▶ Stainless steel construction
- ▶ SAE J518-2 code 62 pressure connections
- ▶ High flow capacity
- ▶ Wide regulated pressure range
- ▶ Tolerates contaminated media
- ▶ Fail-safe motor control options
- ▶ Self venting
- ▶ Surge dampening

Applications

- ▶ Offshore and land-based oil drilling controls
- ▶ BOP control units
- ▶ Pressure sensitive equipment

General Specifications*

Pressure: Supply/Inlet Pressures:	3,000 psi (207 bar) 5,000 psi (345 bar)
Regulated Pressure Range at 3,000 psi Supply Pressure: High Sensitivity: Full Range:	300 - 1600 psi (21 - 110 bar) 300 - 2800 psi (21 - 193 bar)
Regulated Pressure Range at 5,000 psi Supply Pressure: High Sensitivity: Full Range:	500 - 1600 psi (34 - 110 bar) 500 - 3000 psi (34 - 207 bar)
Ambient Temperature Range:	-30° to +185°F (-34° to +85°C)
Inlet Proof Pressure:	7,500 psi (517 bar)
Case Proof Pressure:	4,500 psi (310 bar)
Flow: Flow Rate:	120 GPM (@ 50 ft/s)
Cv Outlet:	17.5
Cv Vent:	1.6
Porting: Supply 1:	1" SAE J518 code 62 flange; NPT or SAE porting option
Supply 2:	1" SAE J518 code 62 flange; NPT or SAE porting option
Outlet (Regulated):	1-1/2" SAE J518 code 62 flange; NPT or SAE porting option
Vent:	1" SAE J518 code 62 flange; NPT or SAE porting option

* See product configurator for additional options.



Materials of Construction: External Components Body, Flanges, & Spring Housing:	316 Series stainless steel
Adjusting Handle, Gear Housing (for motorized models)	Nickel Plated 17-4 ST STL
Hardware:	316 Series stainless steel
Wetted Components Slide, Inlet, Vent & Blocking Plates, Pressure Seals:	400 Stainless steel
Other Internal Wetted Components:	300 Series stainless steel
O'ring Material:	Buna N
Backup Ring Material:	PTFE
Pneumatic Pilot Motor ("F" prefix): Pilot Motor Working Pressure:	Painted steel 80 - 120 psi (5.5 - 8.3 bar)
Porting A & B:	1/4" NPT
Operating Temperature Range:	-30° to +185°F (-34° to +85°C)
Hydraulic Pilot Motor ("G" prefix): Pilot Motor Working Pressure:	Painted steel 400 - 1600 psi (6.9 - 110 bar)
Porting A & B:	SAE for 3/8" tube (Size -6)
Operating Temperature Rating:	-30° to +185°F (-34° to +85°C)
Approximate Shipping Weight**: Manual Unit: Pneumatic Motor Unit: Hydraulic Motor Unit:	85 lbs. (38.6 kg) 105 lbs. (47.6 kg) 105 lbs. (47.6 kg)

** Weight is based on the code 62 flanges

1-1/2" Stainless Steel Pressure Regulator

Series S20517

Technical Drawings

For more detail, see sales drawing

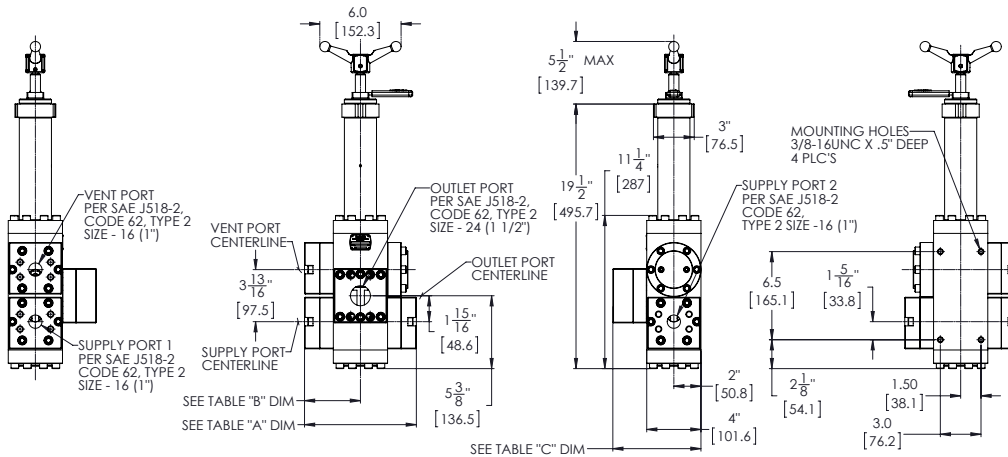

MANUALLY ADJUSTED REGULATOR

PORTING OPTION	DIM "A"	DIM "B"	DIM "C"
SAE J518-2 CODE 62 (SHOWN)	8-1/4"	4-1/8"	6-1/2"
NPT	7"	3-1/2"	5-5/32"
SAE J1926	7"	3-1/2"	5-5/32"

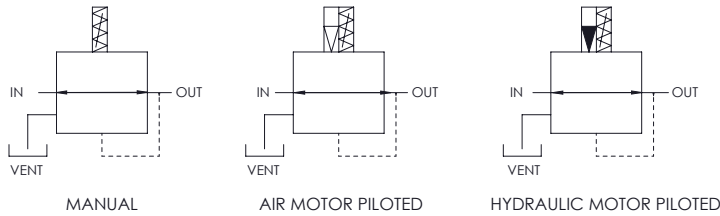

Dimensions in inches [mm]

FLOW PATTERN

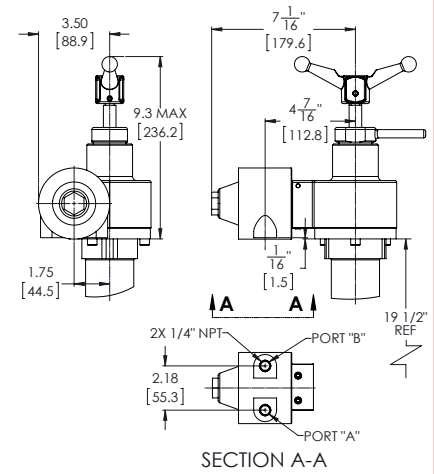

AIR MOTOR PILOTED

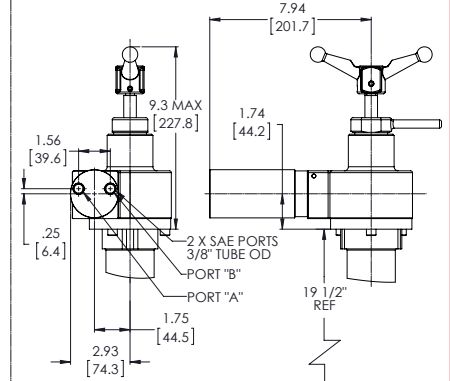

HYDRAULIC MOTOR PILOTED

Product Configurator

Example: **S** **20517S6HQ2**

S Stainless steel pressure regulator

Adjustment Method

Blank	Manual
F	Pneumatic motor
G	Hydraulic motor

Series

20517S6HQ2 1-1/2" Stainless steel pressure regulator

Option

Blank	SAE J518 code 62 flanges (4 bolt)
-NPT	NPT porting
-MS	SAE porting
-BP	Bypass Function

Regulated Pressure Range

		Inlet Pressure	Regulated Range
Blank	High sensitivity	3000 psi	300 - 1600 psi (21 - 110 bar)
		5000 psi	500 - 1600 psi (34 - 110 bar)
-1	Full range	3000 psi	300 - 2800 psi (21 - 193 bar)
		5000 psi	500 - 3000 psi (34 - 207 bar)