

Installation Instructions

DTS-HAZ DTS-HAZ-DC

for Use with Self-Regulating
& Constant Wattage Heating Cables



Chromalox[®]
PRECISION HEAT AND CONTROL

PJ944-9
5625-81049
May 2013

DTS-HAZ

Self-Regulating & Constant Wattage Heating Cables

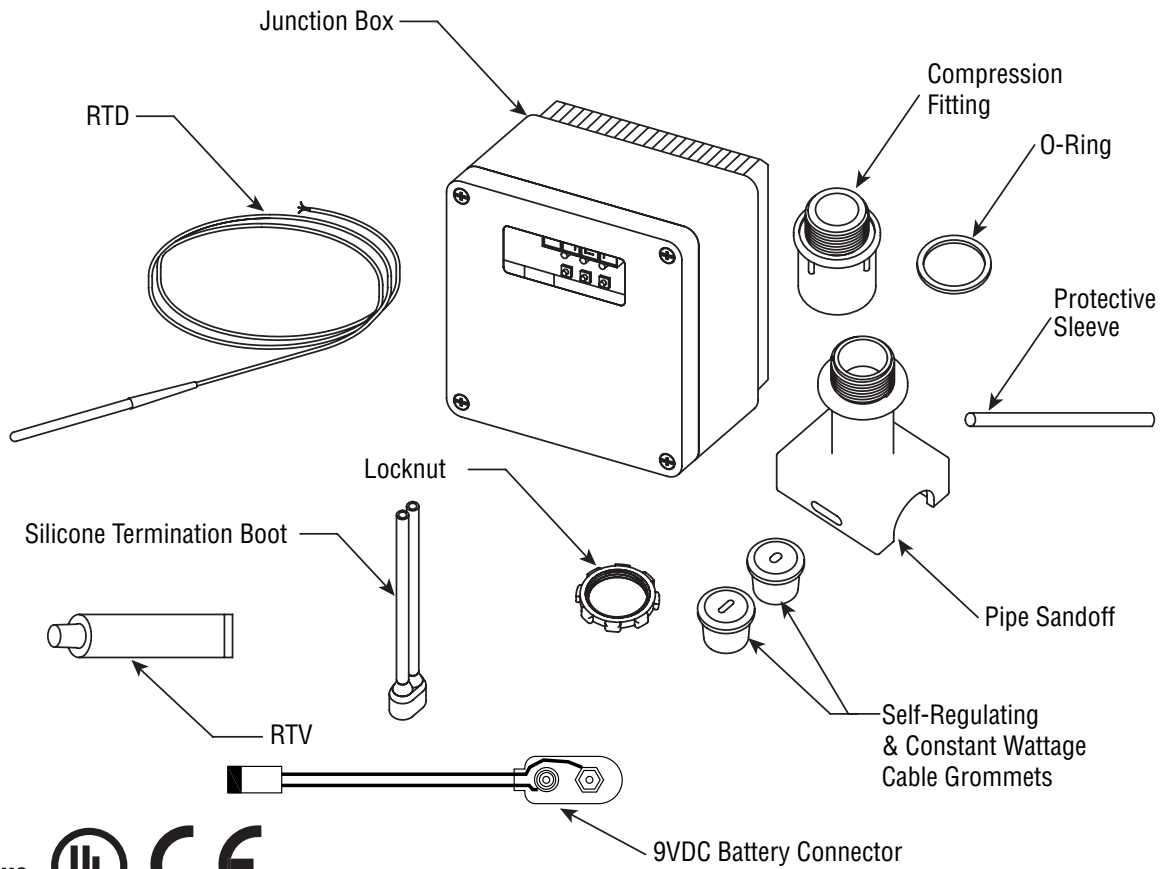

Qty	Description	Qty	Description
1	Junction Box	1	RTV
1	Line/Ambient Sensing RTD	1	O-Ring
1	Compression Fitting	1	Self-Regulating Cable Grommet
1	Locknut 1	1	Constant Wattage Cable Grommet
1	Silicone Termination Boot	1	9 VDC Battery Connector
1	Pipe Standoff	1	Protective Sleeve

General

The DTS-HAZ is used for electrical termination of self-regulating and constant wattage cables. Each kit contains the terminations needed to make all electrical connections.

The DTS-HAZ digital thermostat kit is a microprocessor based temperature control and power connection kit used for freeze protection or process temperature

maintenance of pipes or tanks protected by heat tracing products. This thermostat can be used with Constant Wattage, Mineral Insulated or Self regulating heating cables in ordinary area or Div 2 hazardous area locations.

Explanation of Symbols Used:

 Means **WARNING**.

 Means Earth (ground) terminal.

WARNING

HAZARD OF ELECTRIC SHOCK. Disconnect all power before starting. All installations must be effectively grounded in accordance with the National Electrical Code to eliminate shock hazard.

WARNING

Turn off power before removing junction box cover at all times.

WARNING

Users should install adequate controls and safety devices with their electric heating equipment. Where the consequences of failure may be severe, back-up controls are essential. Although the safety of the installation is responsibility of the user, Chromalox will be glad to assist in making equipment recommendations.

WARNING

A disconnect device and circuit breaker should be provided in the end installation. The installation and proximity for the disconnect device must satisfy the electrical Authority having jurisdiction for the installation. Branch circuit protection should be set for 40 amps or lower.

WARNING

In all cases where the symbol is used on the product, consult the documentation to find out the nature of the potential hazard and any actions to be taken.

**Braid only cable instructions for SRL-C, SRF-C, SRM/E-C.
CWM-C cable special instructions denoted by ***

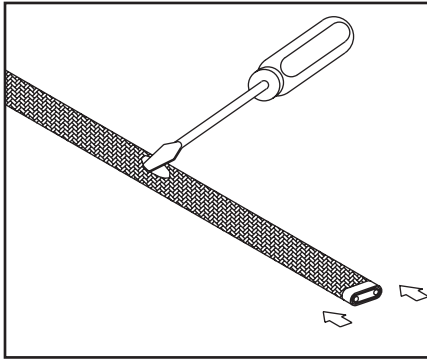

1. For each cable, push braiding back from the end of the cable. 11 inches from cable end create a bulge. At the bulge, separate the braid to make an opening.

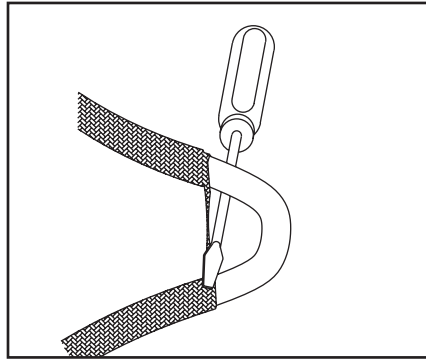

2. While bending the heating cable, work the cable through the braid opening. Pull the braid tight

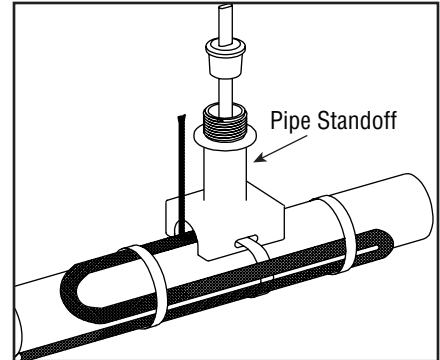

3. Insert cables and capillary tube through pipe standoff and grommet as shown. There should be 8 inches of cable past the grommet's edge. Attach the pipe standoff to the pipe with a pipe strap (Chromalox type PS not included) as shown. Leave braid of the cable outside of pipe standoff and connect to ground (grounding clamp not included). Tape cable to pipe as shown. Small slice will need to be cut in grommet to allow the RTD wire to exit the pipe standoff out the bottom. For pipes smaller than 1-1/2" dia. a small pipe adapter (Chromalox model SPA not included) is required.

Mounting Note: The Pipe Standoff is typically replaced by 1" NPT (straight) rigid conduit when the optional Wall Mounting Bracket is used. See Wall Mount Option.

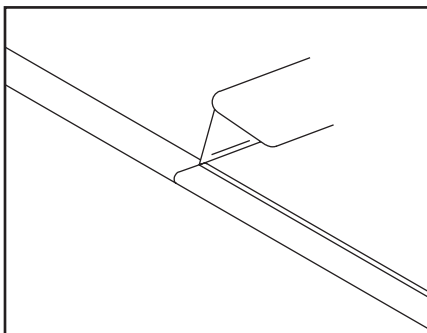

4. Score the inner insulation 7 inches from the end. Lightly cut the inner jacket up the center to end of heating cable and remove the inner jacket from the cable.

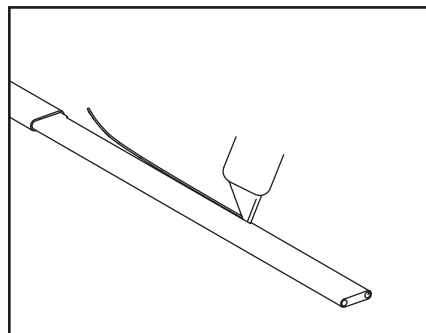

5. Shave the core material from the outside of each bus wire. *Skip this step if using CWM-C constant wattage cable.

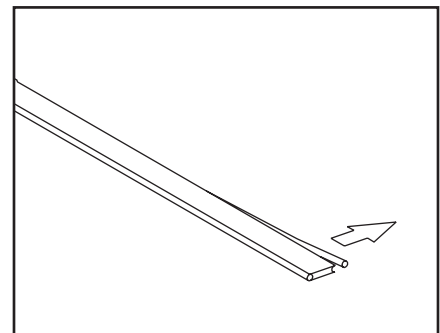

6. Starting at the end of the heating cable, using needle nose pliers or a knife pull each bus wire away from the core material. *Separate CWM-C leads and strip 1/4" from each leadwire.

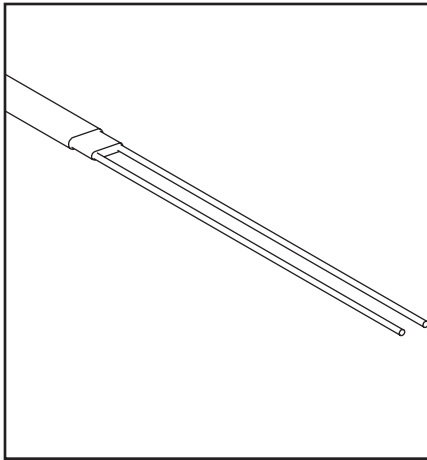

7. Remove the exposed core material and cut 1/4" off the end of each bus wire. *Skip this step if using CWM-C constant wattage cable.

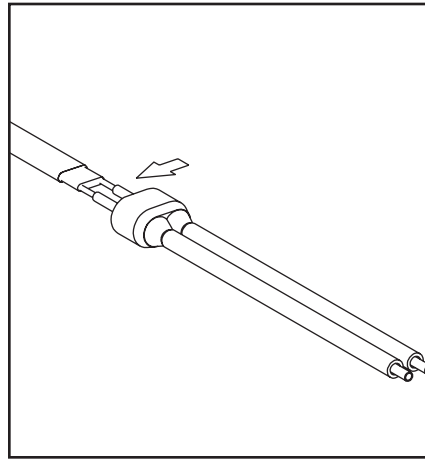

8. Liberally apply RTV over the exposed matrix and leads. Push the rubber boot over the heating cable. Trim lead ends as needed.
*Boot is not needed when using CWM-C constant wattage cable.

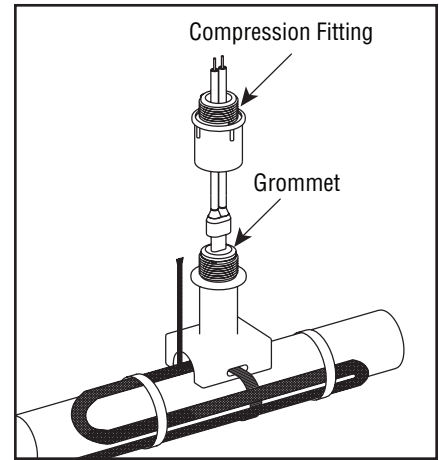

9. Slide compression fitting over cable. Grommet should be placed inside pipe standoff. Termination boot should be spaced 1/2" from sealing grommet. Tighten compression fitting until it bottoms out against pipe standoff.

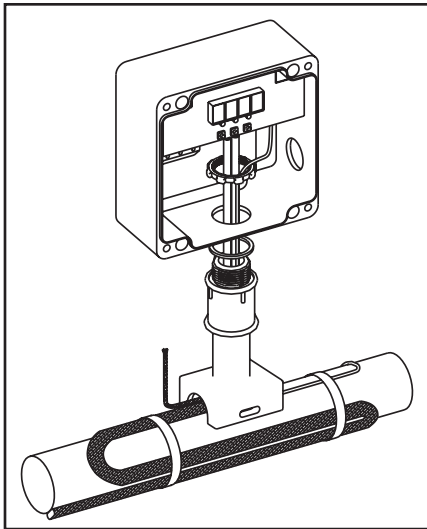

10. Assemble junction box to compression fitting as shown. Tighten locknut until the junction box bottoms out against the lip of the compression fitting.

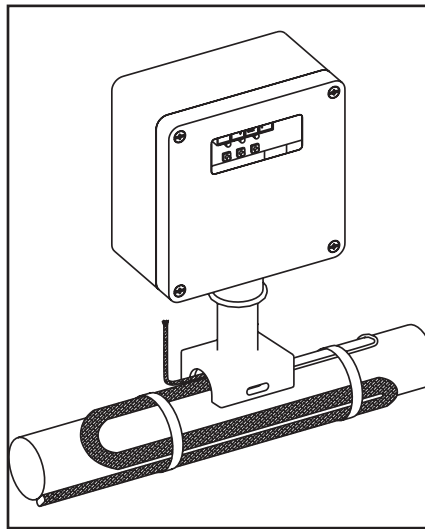

11. Attach 3/4" conduit hub. Please see the electric diagrams below for proper wiring for your application. Attach junction box cover to seal enclosure. Note: The conduit hub shall be listed for Class 1, Div. 2; Class II Div. 1 & 2, Class III, Div. 1 & 2, and 4X rated by a nationally recognized testing laboratory.

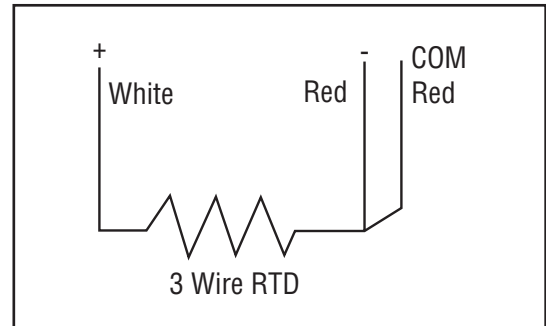
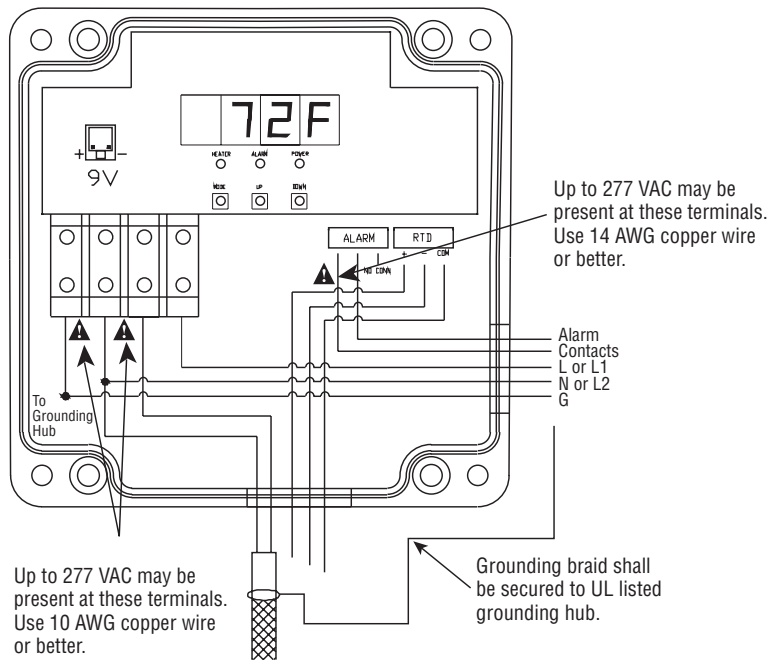

⚠ CAUTION

Be sure to install this device vertically as pictured. This controller utilizes a heat sink which is designed to cool the unit during operation. Under no circumstance should air flow around the controller be compromised in any way. Failure to do so may result in the overheating of the controller, product failure, product temperatures which exceed the Hazardous Area maximum temperature limit and even fire.

⚠ CAUTION

Enclosure lid must be properly sealed prior to operating. Each of the four (4) screws are to be evenly tightened by hand with appropriate screw driver ONLY until snug. It is recommended that the lid be secured with a torque of 12-15 inch-lbs per screw. Overtightening or uneven tightening may cause the lid to break which would void all environmental and hazardous location approvals. Due to an electrical shock hazard, do not operate thermostat if lid is cracked, broken or uneven with enclosure.

⚠ WARNING

The maximum allowable length of the RTD wire is 50ft. (15m) in order to remain UL/cUL compliant.

Overjacketed cable instructions for SRL-CR, SRL-CT, SRF-CR, SRM/E-CT. CWM-CT cable instructions denoted by *

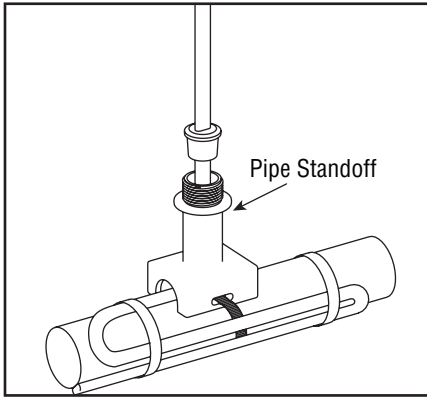

1. Insert heating cable and capillary tube through pipe standoff and grommet as shown. 8 inches of cable should extend past the grommet. Attach the pipe standoff to the pipe with a pipe strap (Chromalox type PS not included) as shown. Attach extra cable to pipe as appropriate. Small slice will need to be cut in grommet to allow the RTD wire to exit the pipe standoff out the bottom. For pipes smaller than 1-1/2" diameter optional small pipe adapter (Chromalox model SPA not included) is required.

Mounting Note: The Pipe Standoff is typically replaced by 1" NPT (straight) rigid conduit when the optional Wall Mounting Bracket is used. See Wall Mount Option.

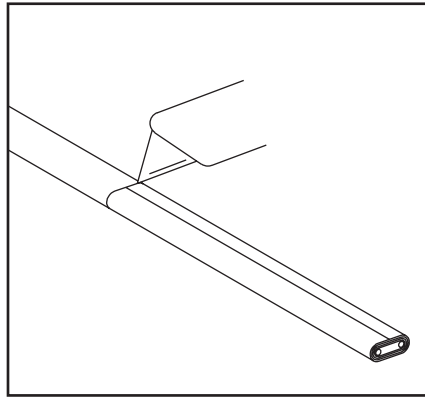

2. Score the outer insulation 7 inches from the end of the cable. Lightly cut the outer jacket up the center to the end of heating cable and remove the outer jacket from the cable. **WARNING: DO NOT CUT METAL BRAID.**

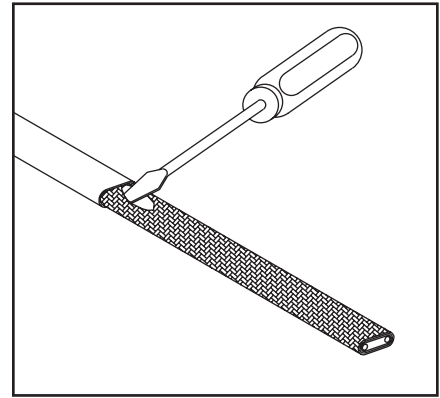

3. Move braid back toward the over-jacket, creating a bulge. At the bulge, separate the braid to make an opening.

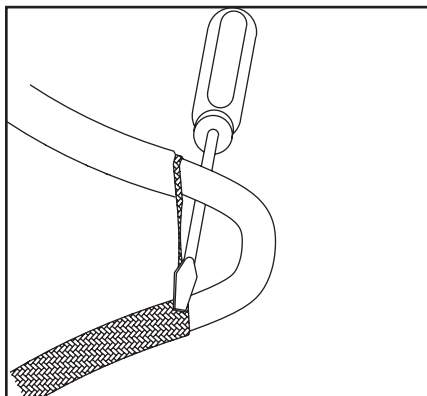

4. While bending the heating cable, work the cable through the braid opening. Pull the braid tight.

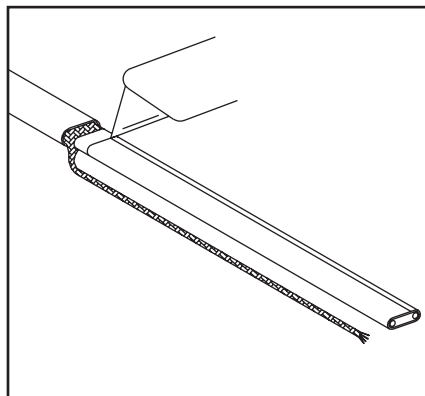

5. Score the inner insulation 6 inches from the end. Lightly cut the inner jacket up the center to end of heating cable and remove the inner jacket from the cable.

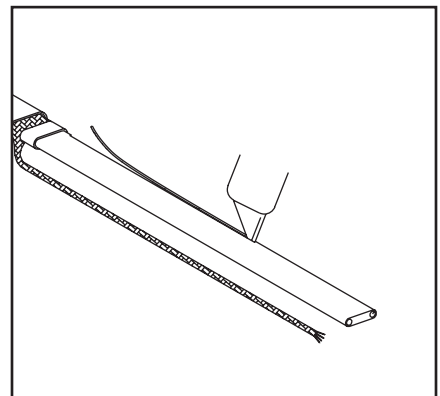

6. Shave the core material from the outside of each bus wire. *Skip this step if using CWM-C constant wattage cable.

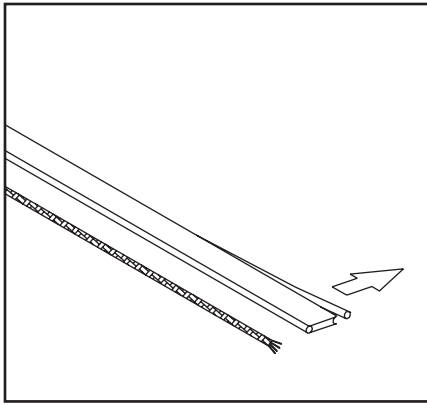

7. Starting at the end of the heating cable, using needle nose pliers or a knife pull each bus wire away from the core material. *Separate CWM-C leads and strip 1/4" from each leadwire.

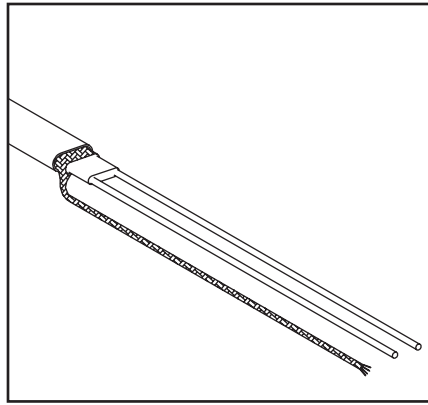

8. Remove the exposed core material and cut 1/4" of the end of each bus wire. *Skip this step if using CWM-C constant wattage cable.

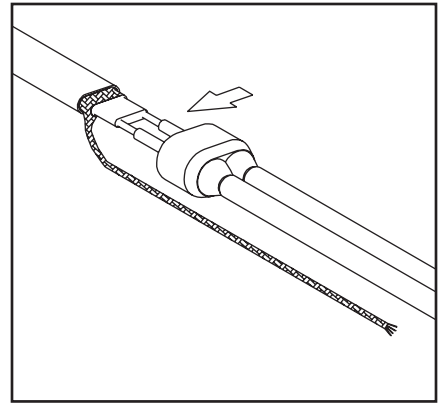

9. Liberally apply RTV over the exposed matrix and leads. Push the rubber boot over the heating cable. Trim lead ends as needed. *Boot is not needed when using CWMC constant wattage cable.

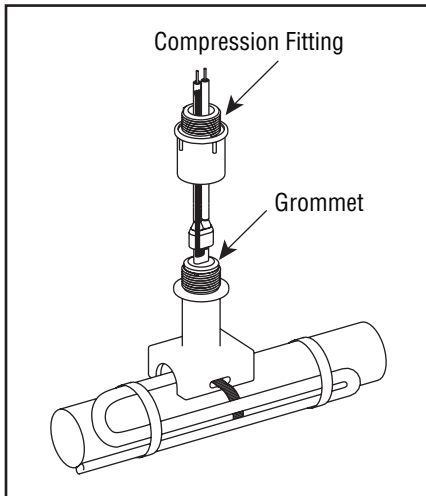

10. Slide compression fitting over cable. Grommet should be placed inside pipe standoff. Termination boot should be spaced 1/2" from sealing grommet. Tighten compression fitting until it bottoms out against pipe standoff.

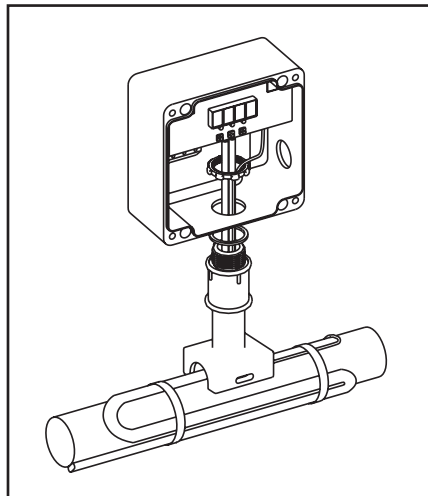

11. Assemble junction box to compression fitting as shown. Tighten locknut until the junction box bottoms out against the lip of the compression fitting.

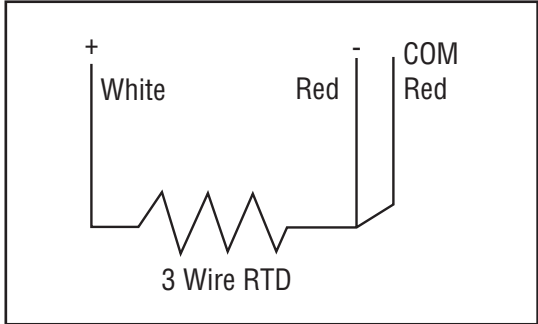
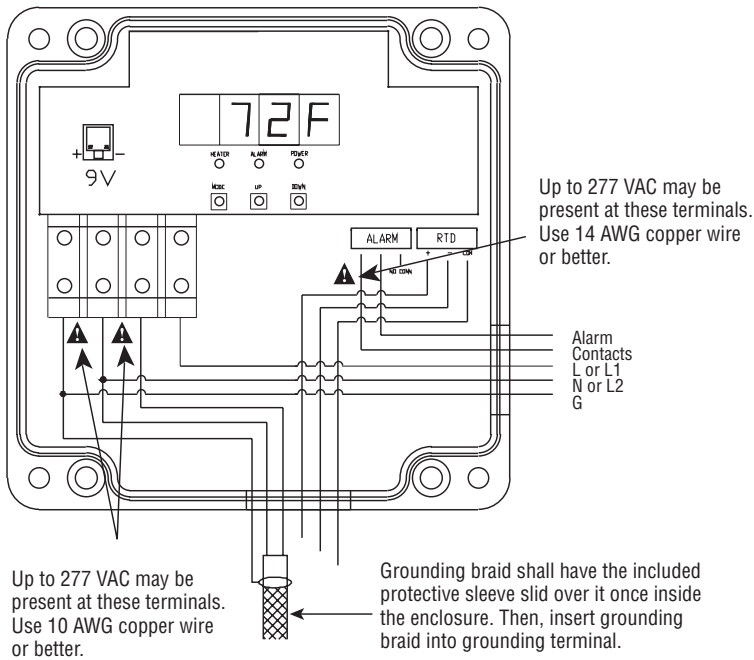

12. Attach 3/4" conduit hub. Please see the electric diagrams below for proper wiring for your application. Attach junction box cover to seal enclosure. For over-jacketed cable with internally grounded braid: Grounding braid shall have the included protective sleeve slid over it once inside the enclosure. Then, insert grounding braid into grounding terminal. Note: The conduit hub shall be listed for Class 1, Div. 2; Class II Div. 1 & 2, Class III, Div. 1 & 2, and 4X rated by a nationally recognized testing laboratory.

⚠ WARNING

The maximum allowable length of the RTD wire is 50ft. (15m) in order to remain UL/cUL compliant.

⚠ CAUTION

Enclosure lid must be properly sealed prior to operating. Each of the four (4) screws are to be evenly tightened by hand with appropriate screw driver ONLY until snug. It is recommended that the lid be secured with a torque of 12-15 inch-lbs per screw. Overtightening or uneven tightening may cause the lid to break which would void all environmental and hazardous location approvals. Due to an electrical shock hazard, do not operate thermostat if lid is cracked, broken or uneven with enclosure.

⚠ CAUTION

Be sure to install this device vertically as pictured. This controller utilizes a heat sink which is designed to cool the unit during operation. Under no circumstance should air flow around the controller be compromised in any way. Failure to do so may result in the overheating of the controller, product failure, product temperatures which exceed the Hazardous Area maximum temperature limit and even fire.

Optional Wall Mount Kit

The DTS-HAZ may be mounted on vertical surfaces. To maintain UL/cUL and Class 1, Division 2 compliance, the user must use the optional Wall Mounting Bracket Kit (MP-2 DTS-HAZ Mounting Plate Kit, part number 5120-13015).

Considerations:

1. The kit comes complete with two stainless steel mounting brackets and the necessary hardware to mount the brackets to the DTS-HAZ.
2. Should the owner use other means to mount the DTS to a vertical surface, a minimum of 3 inches or 76 mm must be maintained from the rear of the DTS-HAZ to the mounting surface. This is necessary to provide adequate airflow across the heat sink at the rear of the DTS.

3. When installing the DTS on a vertical surface, the Pipe Standoff is not used and is typically replaced by rigid 1" NPT conduit. The conduit shall terminate into the Compression Fitting.

Ordering Information:

Wall Mount Kit PCN (Part Number): 318043

Stainless Steel Hardware:

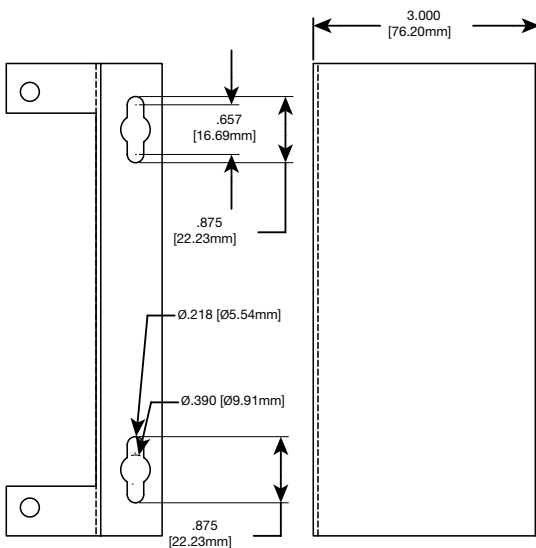
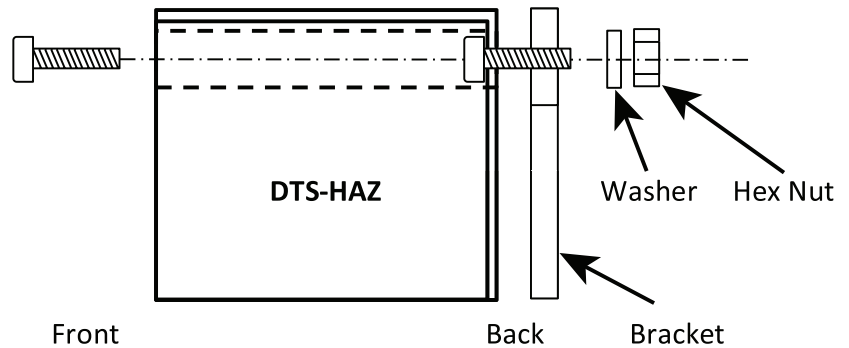
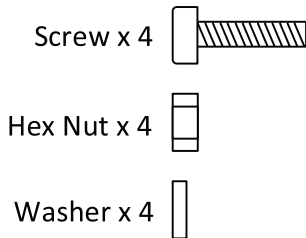

RECOMMENDED - WALL MOUNT LAYOUT MAXIMUM #10 STUD

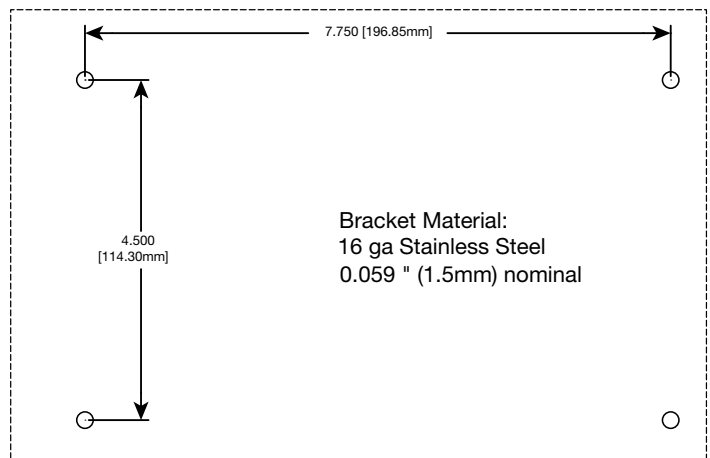

Start-Up

⚠ WARNING

For up to 30 amp loads, use minimum 10 AWG wiring or better for 120/277 VAC power input.

Connecting power to the unit.

1. Powering up with 120/277 VAC: To power up the unit apply 120/277 VAC to the terminal block according to the schematic below:

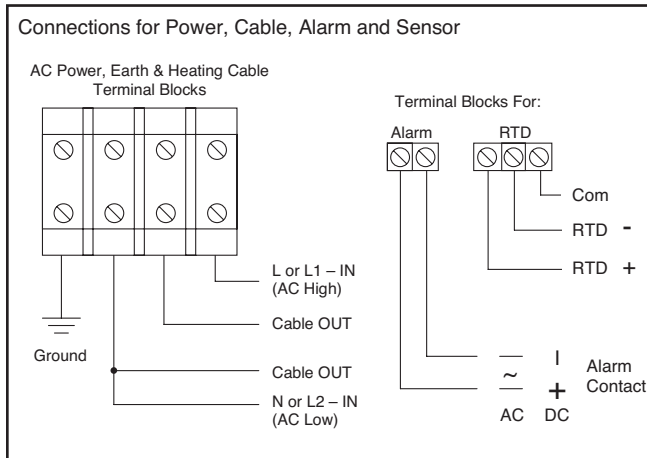

2. Programming with 9VDC battery:

The DTS-HAZ may be programmed with a 9VDC battery should standard service line voltage be unavailable.

Note: Powering unit with 9VDC should only be used for programming purposes and not operation of the unit.

3. Programming and alarm overview

Digital Thermostat must have the following components set to correctly control the temperature:

- a. Setpoint – targeted temperature value that controller will aim to reach
- b. Hi Temperature Threshold – max. temperature value. After reaching this threshold controller will set Alarm condition.

- c. Lo Temperature Threshold – min. temperature value. After reaching this threshold controller will set Alarm condition.
- d. Deadband – The allowable temperature differential between the Set Point and the Sensed Temperature during normal operation. The Deadband is centered on the Setpoint. The Deadband has a range of 2 to 10 deg. in 2 degree increments. The Load is removed once the temperature is 1/2 way between the Setpoint and the upper limit of the Deadband.
- e. Units – selection between degrees Fahrenheit or Celsius.
- f. Soft Start Function – The soft start may be enabled or disabled. When enabled, the Soft start algorithm initiates at power on & whenever low end of dead band is realized. When initiated, 0% - 100% Power is achieved over 167 seconds.
- g. Alarm – The alarm on the DTS-HAZ functions only with AC voltage. The alarm on the DTS-HAZ-DC functions only with DC voltage. The FACTORY DEFAULT SETTING IS NORMALLY CLOSED. You may toggle this setting to Normally Open via the control push buttons.

Connecting RTD Wire

1. Connect RTD wire according to the schematic:

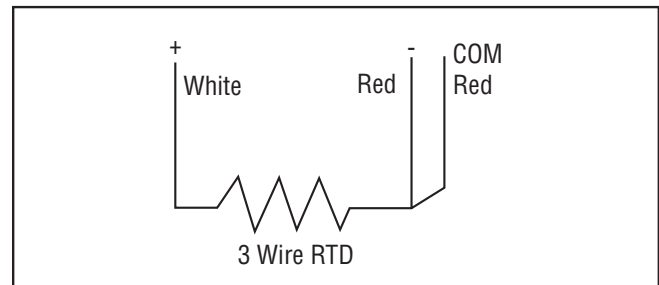

Programming

To Program the Digital Thermostat follow the instructions below:

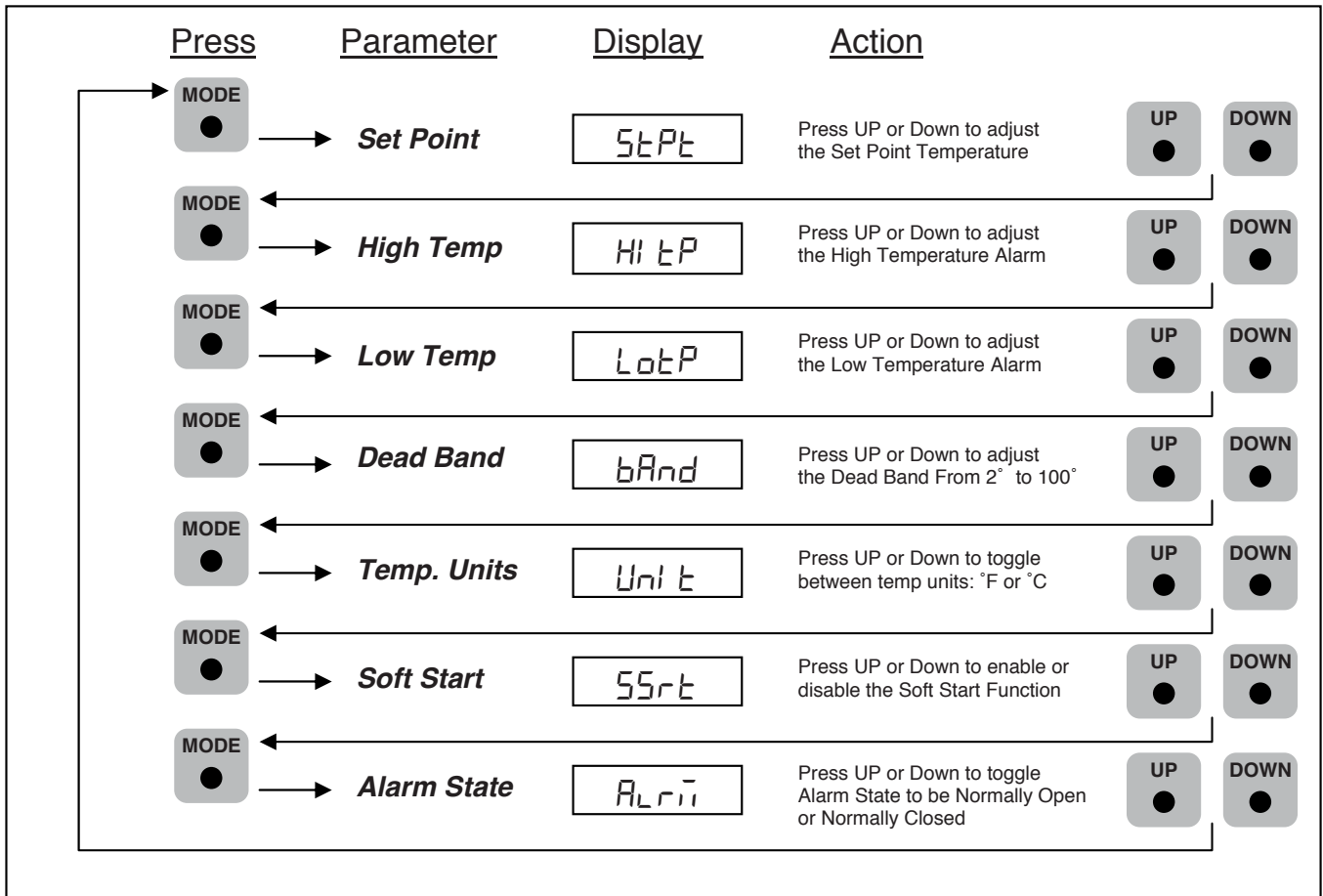

Troubleshooting

Alarm Type:	Display	Solution:
Sensor Open	Sens err	Check if your sensor is correctly connected to the unit
Sensor Shorted	Sens err	Check if your sensor is correctly connected to the unit
Lo Temperature	Blinking between sensed temperature and "LoTP"	Sensed temperature is below Lo Temp. Threshold. Alarm will be cleared automatically when sens temp > lo threshold + 5 deg
Hi Temperature	Blinking between sensed temperature and "HiTP"	Sensed temperature is above HI Temp. Threshold. Alarm will be cleared automatically when sens temp < hi threshold - 5 deg
EPR	EEprom memory error	Press UP & DOWN keys for 2 seconds. Unit will be loaded with default settings
ERR1	Program memory error	Program memory corrupt. Solution: Reprogram the unit. Consult Factory.

Product Maintenance & Care

The following inspections should occur upon receipt of product and at least once every year.

a. Wiring

Inspect wiring for wear, fraying and evidence of overheating. Repair minor defects with a high quality grade of electrical tape or replace if needed.

b. Hardware & Connectors

Inspect for loose electrical and mechanical connections. Tighten or replace all loose or missing hardware.

c. Cleaning

This product does not require cleaning. However, the heat sink fins on back must routinely be inspected for any debris. Remove any debris with a stiff brush or other careful means. Take care not to break any fins. Should any of the fins break, the unit should be replaced.

⚠ WARNING

EXPLOSION HAZARD. Substitution of any component may impair suitability for Class 1, Div. 2.

Equipment Ratings:

Voltage Rating: 100-277 VAC, 50/60 Hz

Current Rating: 30 amps

Ambient Temperature Rating: -40°F to +104°F

Alarm Rating:

- DTS-HAZ: 12-277 Vac and 1.8 Amps RMS
- DTS-HAZ-DC: 0-42 Vdc and 1.8 Amps RMS

VA rating on electronics: 4.0 Watts

The electronics are protected by a 0.5 Amp 350 VAC 2AG fuse

Maximum RTD output 1.25 volts, 7 milliamps

Settings:

Setpoint: -80°F to 1100°F (-62°C to 593°C)

Alarms: High temp to 1150°F (621°C)

Low temp to -80°F (-62°C)

Deadband: 2°F (or °C) to 100°F (or °C)

+/- 1° to 50° around the setpoint

Alarm Function:

Mode	Default	Optional
Normal Operation	Closed	Open
Alarm Condition	Open	Closed
Power Off	Open	Open

Agency Approvals:

UL/cUL - Ordinary area, File number E336917

UL/cUL - Hazardous area (C1D2, Groups A, B, C & D)

- File number E347725

CE

Field Wiring Considerations:

Torque values for field wiring terminals11-15 in-lbs
(1.2 - 1.7 n-m)

Wire gauge range6 - 18 ga

Stripped insertion length 1/2" (12mm)

Replacement Parts

Fuse

Specifications 0.5A, 350V, 2 AG

Dimensions 14.18 mm (L) x 4.5 mm (W)

Material Glass

Vendor & Model Littlefuse, Model 209.500

Replacing Fuse:

⚠ WARNING

HAZARD OF ELECTRIC SHOCK. Turn off power before removing junction box cover.

1. Remove Cover.
2. Carefully remove display board from 4 nylon posts.
3. Fuse is in upper left corner of bottom board.
4. Carefully remove the bad fuse and replace with new fuse.

Limited Warranty:

Please refer to the Chromalox limited warranty applicable to this product at <http://www.chromalox.com/customer-service/policies/termsofsale.aspx>.

Chromalox[®]
PRECISION HEAT AND CONTROL

1347 HEIL QUAKER BLVD., LAVERGNE, TN 37086
Phone: (615) 793-3900 www.chromalox.com