



Back Pressure Type Indicator

LE100

Instruction Manual

IMR01C01-E8

Thank you for purchasing this RKC product. In order to achieve maximum performance and ensure proper operation of the instrument, carefully read all the instructions in this manual. Please place the manual in a convenient location for easy reference.

SYMBOLS

WARNING : This mark indicates precautions that must be taken if there is danger of electric shock, fire, etc., which could result in loss of life or injury.

CAUTION : This mark indicates that if these precautions and operating procedures are not taken, damage to the instrument may result.



: This mark indicates that all precautions should be taken for safe usage.



: This mark indicates important information on installation, handling and operating procedures.



: This mark indicates supplemental information on installation, handling and operating procedures.



: This mark indicates where additional information may be located.



WARNING

- To prevent injury to persons, damage to the instrument and the equipment, a suitable external protection device shall be required.
- All wiring must be completed before power is turned on to prevent electric shock, fire or damage to the instrument and the equipment.
- This instrument must be used in accordance with the specifications to prevent fire or damage to the instrument and the equipment.
- This instrument is not intended for use in locations subject to flammable or explosive gases.
- Do not touch high-voltage connections such as power supply terminals, etc. to avoid electric shock.
- RKC is not responsible if this instrument is repaired, modified or disassembled by other than factory-approved personnel. Malfunction may occur and warranty is void under these conditions.

CAUTION

- This product is intended for use with industrial machines, test and measuring equipment. (It is not designed for use with medical equipment and nuclear energy plant.)
- This is a Class A instrument. In a domestic environment, this instrument may cause radio interference, in which case the user may be required to take additional measures.
- This instrument is protected from electric shock by reinforced insulation. Provide reinforced insulation between the wire for the input signal and the wires for instrument power supply, source of power and loads.
- Be sure to provide an appropriate surge control circuit respectively for the following:
 - If input/output or signal lines within the building are longer than 30 meters.
 - If input/output or signal lines leave the building, regardless the length.

- This instrument is designed for installation in an enclosed instrumentation panel. All high-voltage connections such as power supply terminals must be enclosed in the instrumentation panel to avoid electric shock to operating personnel.
- All precautions described in this manual should be taken to avoid damage to the instrument or equipment.
- If the equipment is used in a manner not specified by the manufacturer, the protection provided by the equipment may be impaired.
- All wiring must be in accordance with local codes and regulations.
- All wiring must be completed before power is turned on to prevent electric shock, instrument failure, or incorrect action. The power must be turned off before repairing work for input break and output failure including replacement of sensor, contactor or SSR, and all wiring must be completed before power is turned on again.
- To prevent instrument damage as a result of failure, protect the power line and the input/output lines from high currents with a suitable overcurrent protection device with adequate breaking capacity such as a fuse, circuit breaker, etc.
- A malfunction in this product may occasionally make control operations impossible or prevent alarm outputs, resulting in a possible hazard. Take appropriate measures in the end use to prevent hazards in the event of malfunction.
- Prevent metal fragments or lead wire scraps from falling inside instrument case to avoid electric shock, fire or malfunction.
- For proper operation of this instrument, provide adequate ventilation for heat dissipation.
- Tighten each terminal screw to the specified torque found in the manual to avoid electric shock, fire or malfunction.
- Do not connect wires to unused terminals as this will interfere with proper operation of the instrument.
- Turn off the power supply before cleaning the instrument.
- Do not use a volatile solvent such as paint thinner to clean the instrument. Deformation or discoloration may occur. Use a soft, dry cloth to remove stains from the instrument.
- To avoid damage to the instrument display, do not rub with an abrasive material or push the front panel with a hard object.
- If this instrument is applied with strong impact, its characteristic change may result. Therefore, do not drop it nor apply the impact to it.
- Do not fully close the measuring tube connecting section. If so, the built-in very low pressure sensor may be damaged.
- Use the back pressure purge gas at a pressure of 20 ± 1 kPa and a flow rate of 50 ± 5 mL/min. If a pressure of more than 21 kPa is directly applied to the LE100, the instrument may fail.
- When applying back pressure, use nitrogen gas of high purity which does not contaminate the liquid. When problem in particular does not have liquid pollution by purge gas, use air or the nitrogen gas which removed garbage and oil content of $0.3 \mu\text{m}$ greater or equal.
- The back pressure purge gas (nitrogen gas) is resistant against corrosive gas or liquid for preventing backward flow. As a semiconductor pressure element is used in the detector of this instrument, the detector may be damaged if exposed to corrosive gas or liquid.
- This instrument measures a change in liquid level by measuring the pressure within a measuring tube inserted in liquid. Leakage through the measuring tube connection may cause measurement error.
- If gas bubble forming affects product quality, etc., use a duplex tube so that they may be exhausted to the atmosphere along the inner surface of the tube.
- In order to maintain the initial performance, before starting measurement (including static pressure measurement) conduct empty adjustment to cancel the amount of zero point drift.
- Do not disconnect the measuring tube with the liquid filled in the tank. If disconnected under the above condition, the liquid may flow backward.
- Before stopping the supply of purge gas (nitrogen gas), wash the tank and also clear away the corrosive atmosphere.
- Do not stop supplying the purge gas with the chemical solution and gas in the tank. If stopped, the chemical solution and gas may flow backward to this instrument through the measuring tube to cause instrument failure. If it is necessary to stop supplying the purge gas, take measures for preventing its counter flow such as installing stop valves so that the chemical solution and gas may not flow backward to this instrument.

NOTICE

- This manual assumes that the reader has a fundamental knowledge of the principles of electricity, process control, computer technology and communications.
- The figures, diagrams and numeric values used in this manual are only for explanation purpose.
- RKC is not responsible for any damage or injury that is caused as a result of using this instrument, instrument failure or indirect damage.
- RKC is not responsible for any damage and/or injury resulting from the use of instruments made by imitating this instrument.
- Periodic maintenance is required for safe and proper operation of this instrument. Some components have a limited service life, or characteristics that change over time.
- Every effort has been made to ensure accuracy of all information contained herein. RKC makes no warranty, expressed or implied, with respect to the accuracy of the information. The information in this manual is subject to change without prior notice.
- No portion of this document may be reprinted, modified, copied, transmitted, digitized, stored, processed or retrieved through any mechanical, electronic, optical or other means without prior written approval from RKC.

CONTENTS

| | |
|---|----|
| 1. PRODUCT CHECK..... | 3 |
| 2. PARTS DESCRIPTION..... | 3 |
| 3. MOUNTING | 4 |
| 3.1 Cautions for Mounting | 4 |
| 3.2 Dimensions | 4 |
| 3.3 Mounting Method..... | 4 |
| 4. CONNECTION OF POWER/OUTPUT CONNECTOR..... | 5 |
| 4.1 Cautions for Connection | 5 |
| 4.2 Connector Pin Configuration | 5 |
| 4.3 Wiring Contents..... | 5 |
| 5. CONNECTION OF TUBE | 7 |
| 5.1 Cautions for Connection..... | 7 |
| 5.2 Connection Method | 7 |
| 5.3 Adjustment of Back Pressure Purge Gas | 7 |
| 5.4 Connection Example | 7 |
| 6. OPERATIONS..... | 8 |
| 6.1 Calling Up Procedure of Each Mode | 8 |
| 6.2 Data Setting Procedure | 9 |
| 6.3 Operating Procedure | 10 |
| 6.3.1 Level is measured in the unit of mm | 10 |
| 6.3.2 Level is measured in the unit of %..... | 12 |
| 6.3.3 Volume is measured in the unit of mL or L | 13 |
| 6.3.4 Pressure is measured in the unit of % | 14 |
| 6.3.5 Pressure is measured in the unit of Pa or kPa | 14 |
| 6.4 Detail of Each Mode | 15 |
| 6.4.1 PV display mode..... | 15 |
| 6.4.2 Operation monitor mode..... | 15 |
| 6.4.3 Amount of emptiness correction monitor mode | 15 |
| 6.4.4 Operation setting mode | 16 |
| 6.4.5 Linearizing table setting mode | 19 |
| 6.4.6 Environment setting mode | 21 |
| 6.4.7 Specific gravity correction setting mode | 25 |
| 6.4.8 Span setting mode..... | 26 |
| 6.4.9 Initialize setting mode | 30 |
| 7. DISPLAY AT ERROR OCCURRENCE..... | 31 |
| 8. SPECIFICATIONS | 32 |

1. PRODUCT CHECK

The LE100 is a level meter with a built-in very low pressure sensor and can also be used as a volumeter or pressure meter.

Before using this product, check each of the following:

- Model code
- Check that all of the items delivered are complete.
- Check that there are no scratch or breakage in external appearance (case, front panel, terminal, etc.).

■ Model code

LE100 - □ 6 * □ □ □ N - □ □
 (1)(2) (3) (4) (5) (6) (7)(8)

(1) Output points

6: 6 points 8: 8 points

(2) Power supply voltage

6: 24 V DC

(3) Contact input (DI) [Optional]

N: No contact input 1: Contact input

(4) Communication [Optional]

N: No communication
 5: RS-485 (RKC communication)

(5) Monitor output [Optional]

N: No monitor output 1: Monitor output

(6) Waterproof/Dustproof

N: No waterproof/dustproof

(7) Connector type

1: 10-pin (Power and Output 6 points)
 2: 16-pin (Power, Output 8 points, Contact input and Communication)

 If LE100 is the following specification, only 16-pin type is selectable.

- Output 8 points
- Contact input (DI)
- Communication (RS-485)

(8) With connector

N: Without connector

- 1: With power/output connector 10-pin type
 Monitor output connector (AWG 28 to 22) is attached when the instrument has the monitor output.
- 2: With power/output connector 16-pin type
 Monitor output connector (AWG 28 to 22) is attached when the instrument has the monitor output.

■ Accessories

Mounting bracket 2 pieces
 LE100 Instruction Manual (IMR01C01-E8) 1 copy
 Power/Output connector (10-pin or 16-pin)..... 1 piece ¹
 Monitor output connector (AWG 28 to 22) 1 piece ²

¹ Only in case of the connector attachment.
² Only in case of the connector attachment and the monitor output is provided.

 If any of the products are missing, damaged, or if your manual is incomplete, please contact RKC sales office or the agent.

■ Other peripherals and accessories (sold separately)

Power/Output cable with connector:
 10-pin type: W-BP-01-□ (□: Cable length)
 16-pin type: W-BP-02-□ (□: Cable length)
 Monitor output cable with connector:
 W-BP-03-□ (□: Cable length)
 Front cover: KMC1B328

2. PARTS DESCRIPTION

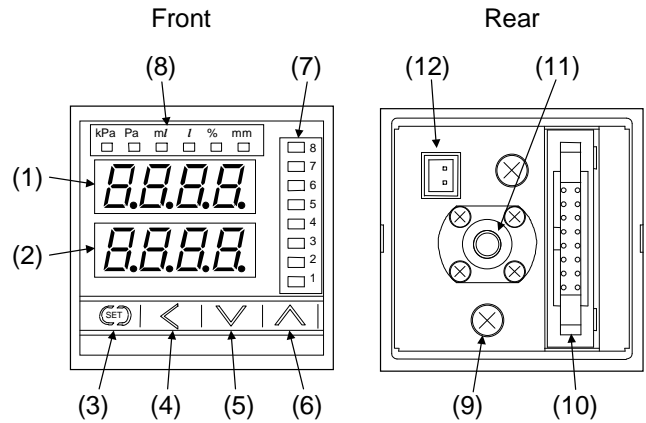

(1) Measured value (PV) display unit [Green]

Displays measured value or various parameter symbols.

(2) Set value display unit [Orange]

Displays various parameters set value.

(3) (SET key)

Used for calling up parameters and set value registration.

(4) (Shift key)

Shifts digits when settings are changed.

(5) (Down key)

Decreases numerals.

(6) (Up key)

Increases numerals.

(7) Output lamps [Green]

Lights when output is turned on.

1: OUT1 2: OUT2 3: OUT3 4: OUT4
 5: OUT5 6: OUT6 7: OUT7 8: OUT8

(8) Unit lamps [Green]

The used engineering unit lights.

kPa, Pa, mL, L, %, mm

 If the unit is set to mL or L, and level is selected for displaying either volume or level, the mL or L unit lamp lights and also the mm unit lamp flashes.

(9) Ground terminal

Screw size: M3 × 6

Recommended tighten torque: 0.4 N·m [4 kgf·cm]

(10) Power/Output connector

There are 10-pin type and 16-pin type in connector.

(Specify when ordering.)

10-pin type: Used to connect the power and output.

16-pin type: Used to connect the power, output, contact input (DI) and communication.

(11) Measuring tube connecting base

Used to connect the measuring tube.

(12) Monitor output connector [Optional]



To avoid damage to the instrument, never use a sharp object to press keys.

3. MOUNTING



WARNING

To prevent electric shock or instrument failure, always turn off the power before mounting or removing the instrument.

3.1 Cautions for Mounting

- (1) This instrument is intended to be used under the following environmental conditions. **(IEC 61010-1)**
[OVERVOLTAGE CATEGORY II, POLLUTION DEGREE 2]
- (2) Use this instrument within the following environment conditions:
 - Allowable ambient temperature: 0 to 50 °C
 - Allowable ambient humidity: 45 to 85 %RH
(Absolute humidity: MAX.W.C 29 g/m³ dry air at 101.3 kPa)
 - Installation environment conditions: Indoor use
Altitude up to 2000 m
- (3) Avoid the following conditions when selecting the mounting location:
 - Rapid changes in ambient temperature which may cause condensation.
 - Corrosive or inflammable gases.
 - Direct vibration or shock to the mainframe.
 - Water, oil, chemicals, vapor or steam splashes.
 - Excessive dust, salt or iron particles.
 - Excessive induction noise, static electricity, magnetic fields or noise.
 - Direct air flow from an air conditioner.
 - Exposure to direct sunlight.
 - Excessive heat accumulation.
- (4) Install the LE100 above the top of the tank. If the LE100 is installed below the measuring tank, malfunction may result and also the liquid may flow backward when a supply of the purge gas is suspended to cause failure.
- (5) Mount this instrument in the panel considering the following conditions:
 - Provide adequate ventilation space so that heat does not build up.
 - Do not mount this instrument directly above the equipment that generates large amount of heat (heaters, transformers, semi-conductor functional devices, large-wattage resistors.)
 - If the ambient temperature rises above 50 °C, cool this instrument with a forced air fan, cooler, etc. Cooled air should not blow directly on this instrument.
 - In order to improve safety and the immunity to withstand noise, mount this instrument as far away as possible from high voltage equipment, power lines, and rotating machinery.
High voltage equipment: Do not mount within the same panel.
Power lines: Separate at least 200 mm.
Rotating machinery: Separate as far as possible.
 - For correct functioning mount this instrument in a horizontal position.
- (6) In case this instrument is connected to a supply by means of a permanent connection, a switch or circuit-breaker shall be included in the installation. This shall be in close proximity to the equipment within easy reach of the operator. It shall be marked as the disconnecting device for the equipment.

3.2 Dimensions

■ External dimensions

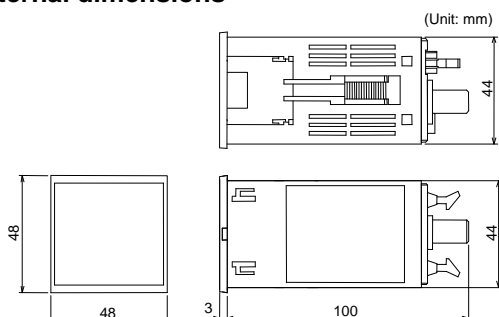

■ Panel cutout

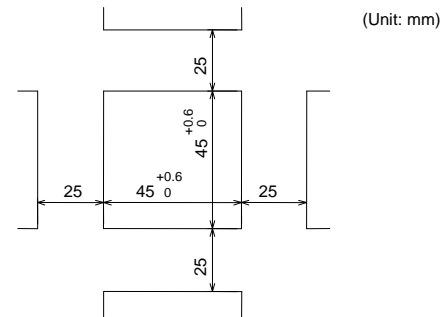

LE100 corresponds to a panel thickness of 1 to 10 mm.

3.3 Mounting Method

<Mounting Procedures>

1. Prepare the panel cutout as specified in **3.2 Dimensions**.
(Panel thickness: 1 to 10 mm)
2. Insert the instrument through the panel cutout.
3. Insert the mounting bracket into the mounting groove of the instrument. Do not push the mounting bracket forward. (Fig. 1)
Part number of mounting bracket: KCA400-532
4. Secure the bracket to the instrument by tightening the screw.
5. Only turn about one full revolution after the screw touches the panel. (Fig. 2)

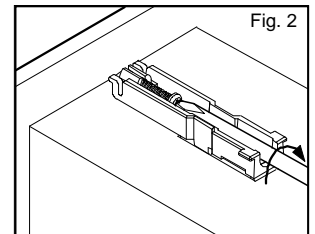
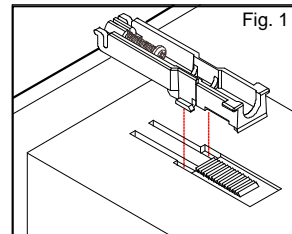

If the screw has been rotated too tight, the screw may turn idle. In such a case, loosen the screw once and tighten it again until the instrument is firmly fixed.

6. The other mounting bracket should be installed in the same way as described in **3. to 5.**

<Removal Procedures>

1. Turn the power OFF.
2. Remove the wiring.
3. Loosen the screw of the mounting bracket.
4. Hold the mounting bracket by the edge (①) and tilt it (②) to remove from the case. (Fig. 3)

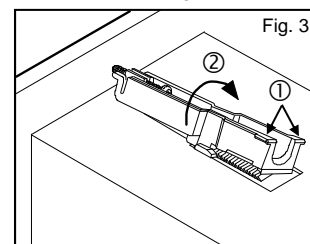

5. The other mounting bracket should be removed in the same way as described in **3. and 4.**
6. Pull out the instrument from the mounting cutout while holding the front panel frame of this instrument. (Fig. 4)

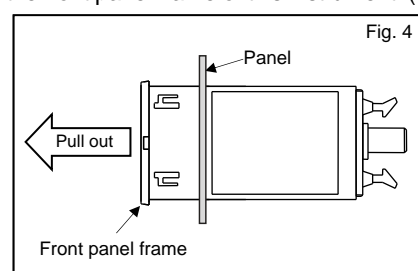

4. CONNECTION OF POWER/OUTPUT CONNECTOR



WARNING

- To prevent electric shock or instrument failure, do not turn on the power until all wiring is completed. Make sure that the wiring is correct before applying power to the instrument.
- To prevent electric shock or instrument failure, turn off the power before connecting or disconnecting the instrument and peripheral equipment.

4.1 Cautions for Connection

- Conduct instrument power wiring so as not to be influenced by noise from the electric equipment power. If the instrument may be affected by external noise, a noise filter should be used.
 - Install the noise filter on the panel which is always grounded and minimize the wiring distance between the noise filter output side and the instrument power terminals.
 - Do not install fuses and/or switches on the filter output signal since this may lessen filter effect.
- This instrument with 24 V power supply is not provided with an overcurrent protection device. For safety install an overcurrent protection device (such as a fuse) with adequate breaking capacity close to the instrument.
 - Fuse type: Time-lag fuse (Approved fuse according IEC 60127-2 and/or UL 248-14)
 - Fuse rating: Rated current: 0.5 A
- For an instrument with 24 V power supply input, supply power from "SELV" circuit defined as IEC 60950-1.
- A suitable power supply should be considered in end-use equipment. The power supply must be in compliance with a limited-energy circuits (maximum available current of 8 A).
- Connect connectors correctly in the right position. If it is forcibly pushed in with pins in the wrong positions, the pins may be bent resulting in instrument failure.
- In order to prevent the instrument from malfunctioning, firmly connect the connector. Check that the Power/Output connector is locked with the lock lever.
- Make sure that during field wiring parts of conductors cannot come into contact with adjacent conductive parts.

4.2 Connector Pin Configuration

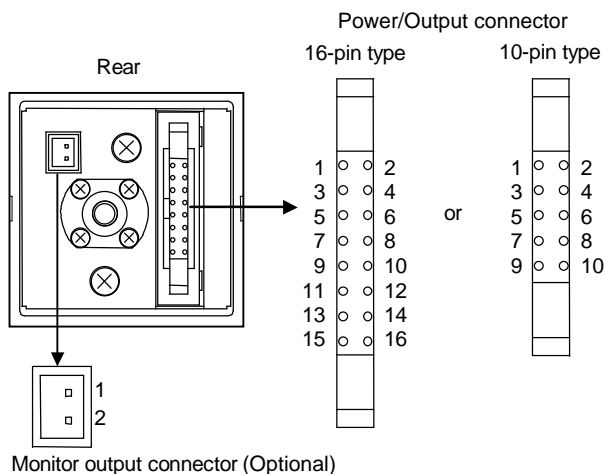

<Model code>

Power/Output connector:

10-pin type: LE100-66 * NN□N-1□

16-pin type: LE100-□6 * □□□N-2□

Monitor output connector:

S2B-XH-A (Manufactured by J.S.T. MFG. CO., LTD.)

Power/Output connector: 10-pin type

| Pin No. | Description |
|---------|---------------------------------|
| 1 | OUT1: Output 1 |
| 2 | OUT2: Output 2 |
| 3 | OUT3: Output 3 |
| 4 | OUT4: Output 4 |
| 5 | OUT5: Output 5 |
| 6 | OUT6: Output 6 |
| 7 | 24 V DC (-)/Output common (COM) |
| 8 | 24 V DC (-)/Output common (COM) |
| 9 | 24 V DC (+) |
| 10 | 24 V DC (+) |

Power/Output connector: 16-pin type

| Pin No. | Description |
|---------|---|
| 1 | T/R (A): RS-485 send/receive data |
| 2 | T/R (B): RS-485 send/receive data |
| 3 | SG: Signal ground/DI (-): Contact input |
| 4 | DI (+): Contact input |
| 5 | OUT1: Output 1 |
| 6 | OUT2: Output 2 |
| 7 | OUT3: Output 3 |
| 8 | OUT4: Output 4 |
| 9 | OUT5: Output 5 |
| 10 | OUT6: Output 6 |
| 11 | OUT7: Output 7 |
| 12 | OUT8: Output 8 |
| 13 | 24 V DC (-)/Output common (COM) |
| 14 | 24 V DC (-)/Output common (COM) |
| 15 | 24 V DC (+) |
| 16 | 24 V DC (+) |

Monitor output connector

| Pin No. | Description |
|---------|--------------------|
| 1 | Monitor output (+) |
| 2 | Monitor output (-) |



Only for the specification with monitor output, the connector is provided.

4.3 Wiring Contents

■ Power/Output connector

The customer must prepare the cable.

Connector used (Manufactured by Japan Aviation Electronics Industry, Limited)

10-pin type: PS-10PE-D4LT1-LP1

16-pin type: PS-16PE-D4LT2-M1

Recommended connector (Manufactured by Japan Aviation Electronics Industry, Limited)

10-pin type: Socket connector PS-10SEN-D4P1-1C

Strain relief PS-SRN10

16-pin type: Socket connector PS-16SM-D4P1-1C

Strain relief PS-SR16M

These connectors and cable are also available from RKC.

● Power supply voltage

Power supply voltage:

21.6 to 26.4 V DC [Including power supply voltage variation],

Rating: 24 V DC

Consumption current:

130 mA max. (at 24 V DC)

● **Output**

Open collector output

- Load voltage: 24 V DC (31.2 V DC max.)
- Maximum load current: 60 mA DC
- Leak current when OFF: 0.1 mA DC or less
- Maximum voltage drop at ON: 2.4 V DC or less
(At a load current of 60 mA DC)

Wiring example (open collector output)

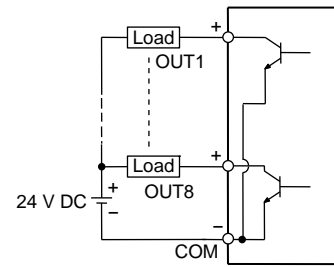

● **Contact input [Optional]**

Dry contact input rated

- Resistance value at contact opens: 500 kΩ or more
- Resistance value at contact closed: 10 Ω or less

● **Communication RS-485 [Optional]**

Connection example: Connection to the RS-485 port of the host computer

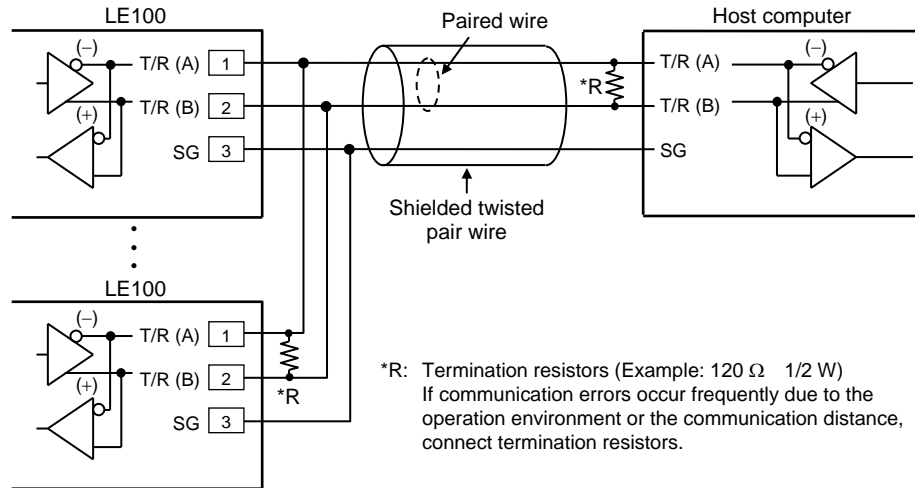

*R: Termination resistors (Example: 120 Ω 1/2 W)
If communication errors occur frequently due to the operation environment or the communication distance, connect termination resistors.

Maximum connections: 32 instruments (including a host computer)

Connection example: Connection to the RS-232C port of the host computer

Use a RS-232C/RS-485 converter with an automatic send/receive transfer function.

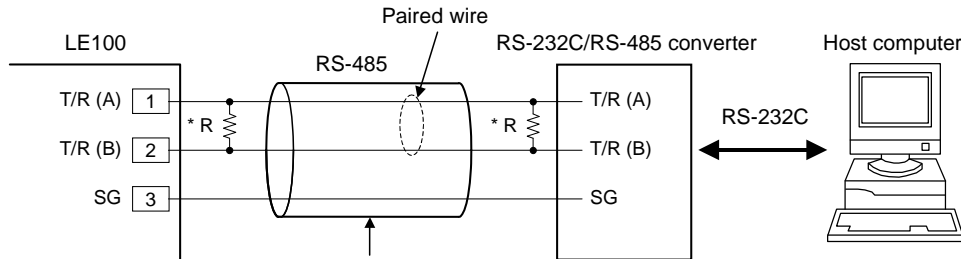

Recommended: CD485, CD485/V manufactured by Data Link, Inc. or equivalent.

* R: Termination resistors (Example: 120 Ω, 1/2 W)
If communication errors occur frequently due to the operation environment or the communication distance, connect termination resistors.



When the host computer is corresponding to the USB connector, our communication converter COM-K2 (sold separately) can be used.



The cable and termination resistor(s) must be provided by the customer.

■ **Monitor output connector [Optional]**

The customer must prepare the cable.

Recommended connector (Manufactured by J.S.T. MFG. CO., LTD.)

- Contact: SXH-001T-P0.6 (AWG 28 to 22)
- SXH-002T-P0.6 (AWG 30 to 26)

Housing: XHP-2

These connectors and cable are also available from RKC.

● **Monitor output**

Voltage output

- Output voltage: 0.0 to 2.5 V DC
- Allowable load resistance: 1 kΩ or more
- Output impedance: 0.1 Ω or less

5. CONNECTION OF TUBE

5.1 Cautions for Connection

- Use the measuring tube without any scratches on its surface. If it is scratched after its frequent use, cut its scratched section.
- Do not extremely bend the measuring tube at the location near the quick fitting.
- The measuring tubes bending or curving may cause a measurement error. Therefore, it should always be straight.
- Install the measuring tubes so that they may not be crushed.
- It is recommended that the end of measuring tube be located at a distance of 5 to 50 mm from the bottom of the tank.
- If the measuring tube is dislocated, a measurement error may result. Therefore, firmly fix the tube so that it may not be dislocated.
- Connect the measuring tube to the LE100 so that the distance between the end of the tube and the LE100 can be 5 m or less.
- This instrument measures a change in liquid level by measuring the pressure within a measuring tube inserted in liquid. Leakage through the tube connection may cause measurement error.

5.2 Connection Method

The customer must prepare the quick fitting and measuring tube.

Recommended quick fitting: PC6-M5SUS (Manufactured by NIHON PISCO Co., LTD.)
TS6-M5-SUS (Manufactured by KOGANEI CORPORATION)

Recommended measuring tube: Fluorine contained resin tube (New PFA) $\phi 6 \times \phi 4$

1. Engage the quick fitting with the measuring tube connecting base (M5 \times 10).
2. Insert the measuring tube into the quick fitting. Check that it is firmly connected to the quick fitting by pulling it out.

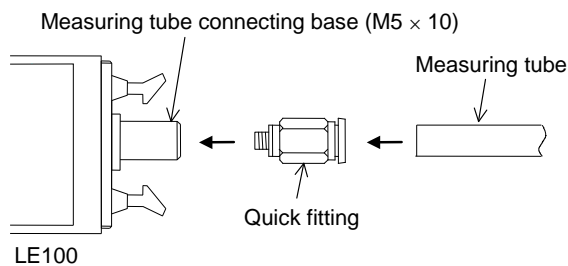

5.3 Adjustment of Back Pressure Purge Gas



- When applying back pressure, use nitrogen gas of high purity which does not contaminate the liquid. When problem in particular does not have liquid pollution by purge gas, use air or the nitrogen gas which removed garbage and oil content of 0.3 μm greater or equal.
- Use the back pressure purge gas at a pressure of 20 ± 1 kPa and a flow rate of 50 ± 5 mL/min. If a pressure of more than 21 kPa is directly applied to the LE100, the instrument may fail.
- Do not pressurize the measuring tank.
- Measure only one tank using one set of the LE100.

1. Gradually open the regulator to set the gas pressure to 20 ± 1 kPa.
2. Set the purge gas flow rate to 50 ± 5 mL/min. (Fixed orifice: Approx. 50 to 80 mL/min)
3. Turn the power of the LE100 on, then conduct the initial setting and emptiness adjustment. Conduct this empty adjustment with the end of the tube opened to the atmosphere.

For the initial setting and emptiness adjustment, refer to **6. OPERATIONS (P. 8)**.

5.4 Connection Example

1. Connect a regulator, fixed orifice and union tee.
2. Connect the LE100 to the union tee.

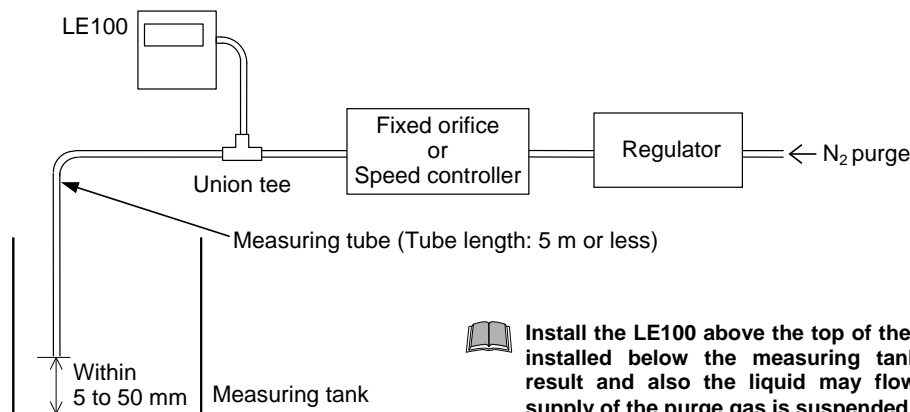

Install the LE100 above the top of the tank. If the LE100 is installed below the measuring tank, malfunction may result and also the liquid may flow backward when a supply of the purge gas is suspended to cause failure.

6. OPERATIONS

Prior to power on, check that the mounting and wiring have been finished.

- ☞ For the mounting procedure, refer to the **3. MOUNTING (P. 4)**.
- ☞ For the wiring procedure, refer to the **4. CONNECTION OF POWER/OUTPUT CONNECTOR (P. 5)** and **5. CONNECTION OF TUBE (P. 7)**.

6.1 Calling Up Procedure of Each Mode

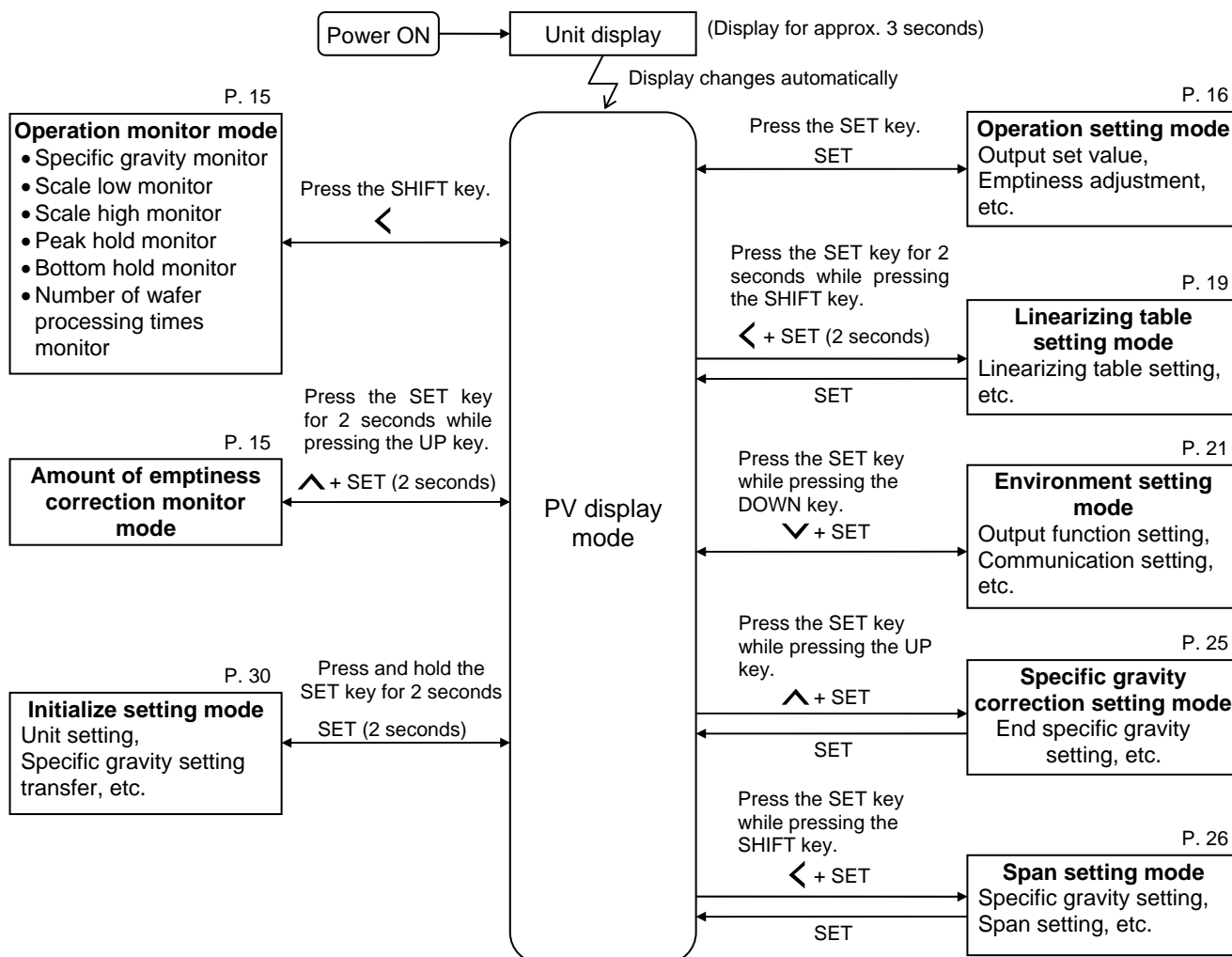

☞ There are modes which are not displayed depending on the specifications.

☞ Pressing the DOWN key while pressing the UP key regardless of the mode now on display can return to the PV display mode.

■ Unit display

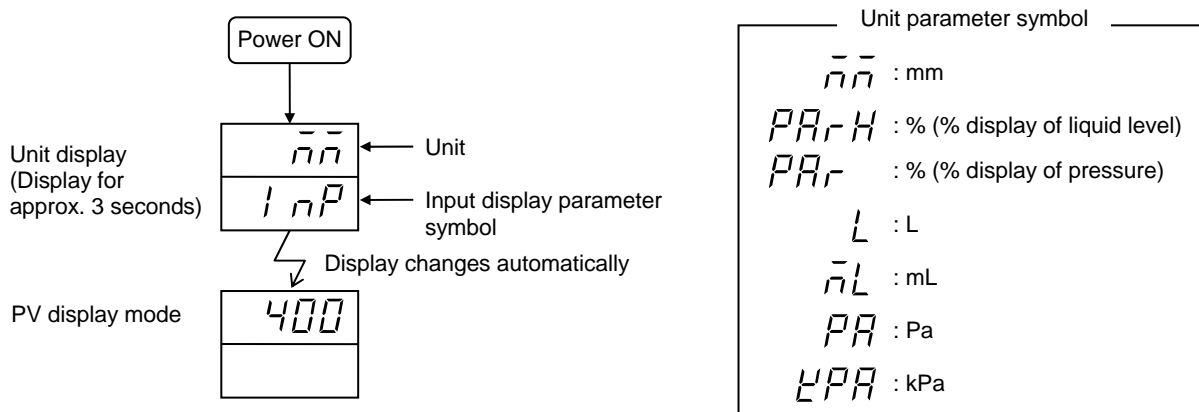

6.2 Data Setting Procedure

Here, an example of changing the output 2 set value to 200 mm is shown. Other data can also be set by the same procedure.



Even if the displayed value is changed, it is not registered. To register it, press the SET key.



If the set data is lock, all of the digits on the set value display unit are brightly lit and the set value cannot be changed.

[Example] Setting the output 2 set value to 200 mm

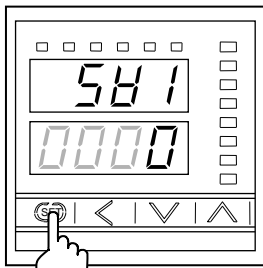

Output 1 set value

1. Press the SET key to enter the operation setting mode.
The first parameter to be displayed will be the output 1 set value.

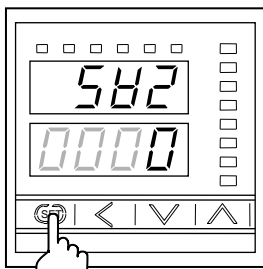

Output 2 set value

2. Press the SET key to enter the output 2 set value.

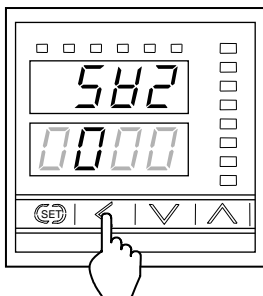

3. Press the SHIFT key to high-light the third digit from the right.

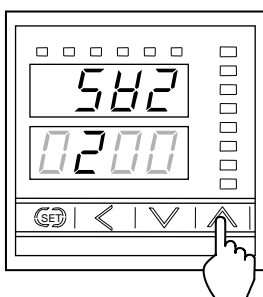

4. Press the UP key to enter 2 at the third digit form the right.

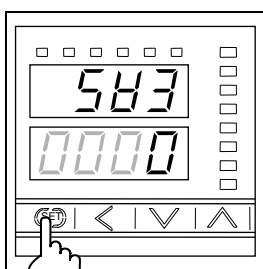

Output 3 set value

5. Press the SET key to store the output 2 set value. The display automatically goes to the next parameter symbol.

6.3 Operating Procedure

The operation procedure differs depending on the engineering unit used.

● **Level meter**

Measured in the engineering unit of mm.

When the specific gravity is known.

Refer to 6.3.1 item, ■ **When the specific gravity is known (P. 10).**

When the specific gravity is unknown.

Refer to 6.3.1 item, ■ **When the specific gravity is unknown (P. 11).**

Level is measured in the engineering unit of %.

When the specific gravity is known.

Refer to 6.3.2 item, ■ **When the specific gravity is known (P. 12).**

When the specific gravity is unknown.

Refer to 6.3.2 item, ■ **When the specific gravity is unknown (P. 12).**

● **Volumeter**

Measured in the engineering unit of mL or L.

When the specific gravity is known.

Refer to 6.3.3 item, ■ **When the specific gravity is known (P. 13).**

When the specific gravity is unknown.

Refer to 6.3.3 item, ■ **When the specific gravity is unknown (P. 13).**

● **Pressure meter**

Pressure is measured in the engineering unit of %.

Refer to 6.3.4 item (P. 14).

Measured in the engineering unit of Pa or kPa.

Refer to 6.3.5 item (P. 14).

6.3.1 Measured in the unit of mm

■ **When the specific gravity is known**

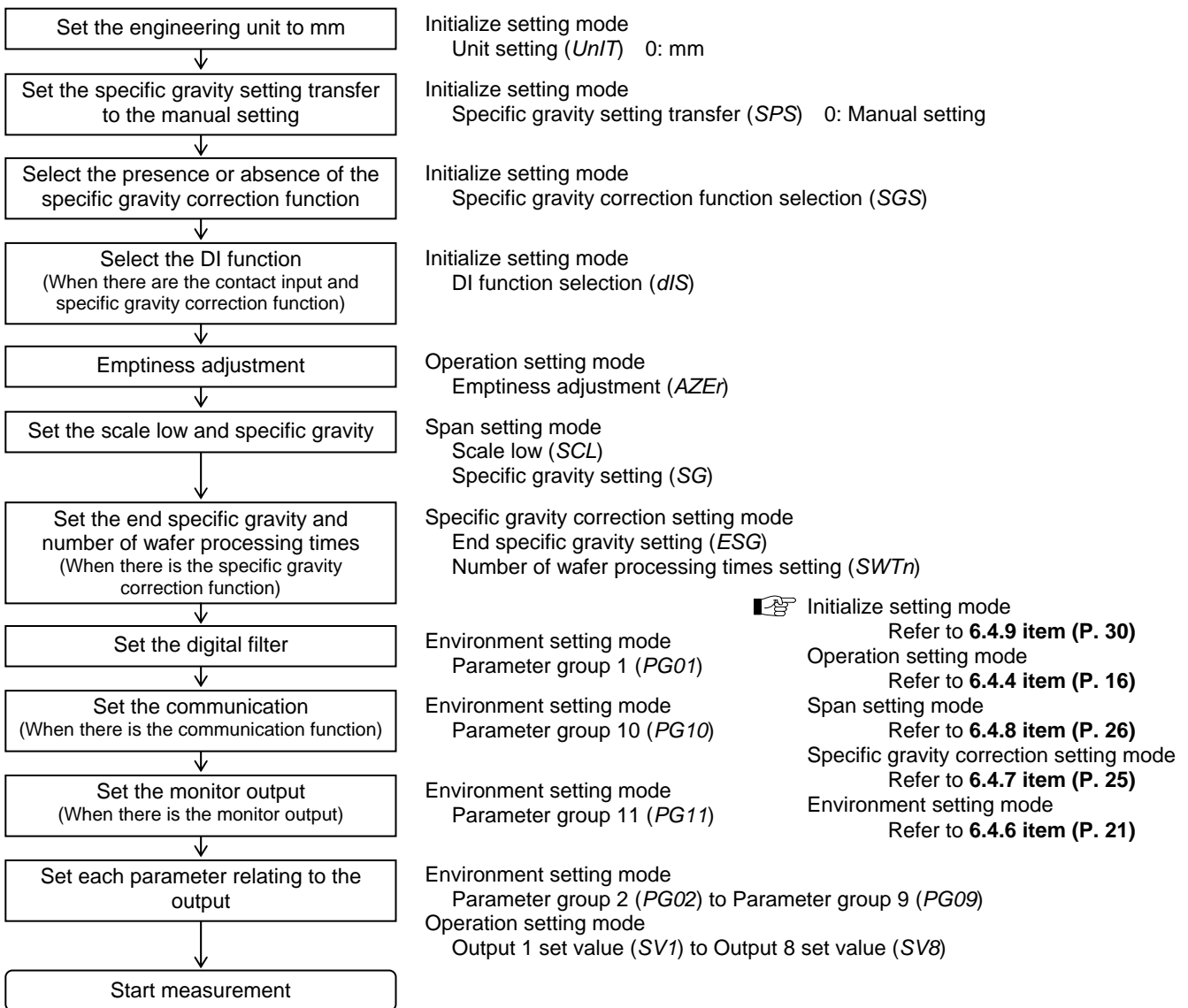

■ When the specific gravity is unknown



When setting the span by using the actual liquid whose specific gravity is unknown, leave a space between scale 1 actual liquid setting and scale 2 actual liquid setting as wide as possible within the measuring range (which may differ depending on the height of the tank used). The narrower the span, the larger the error of height (or volume) out of the measuring range. This setting is possible while the liquid is being charged or discharged.

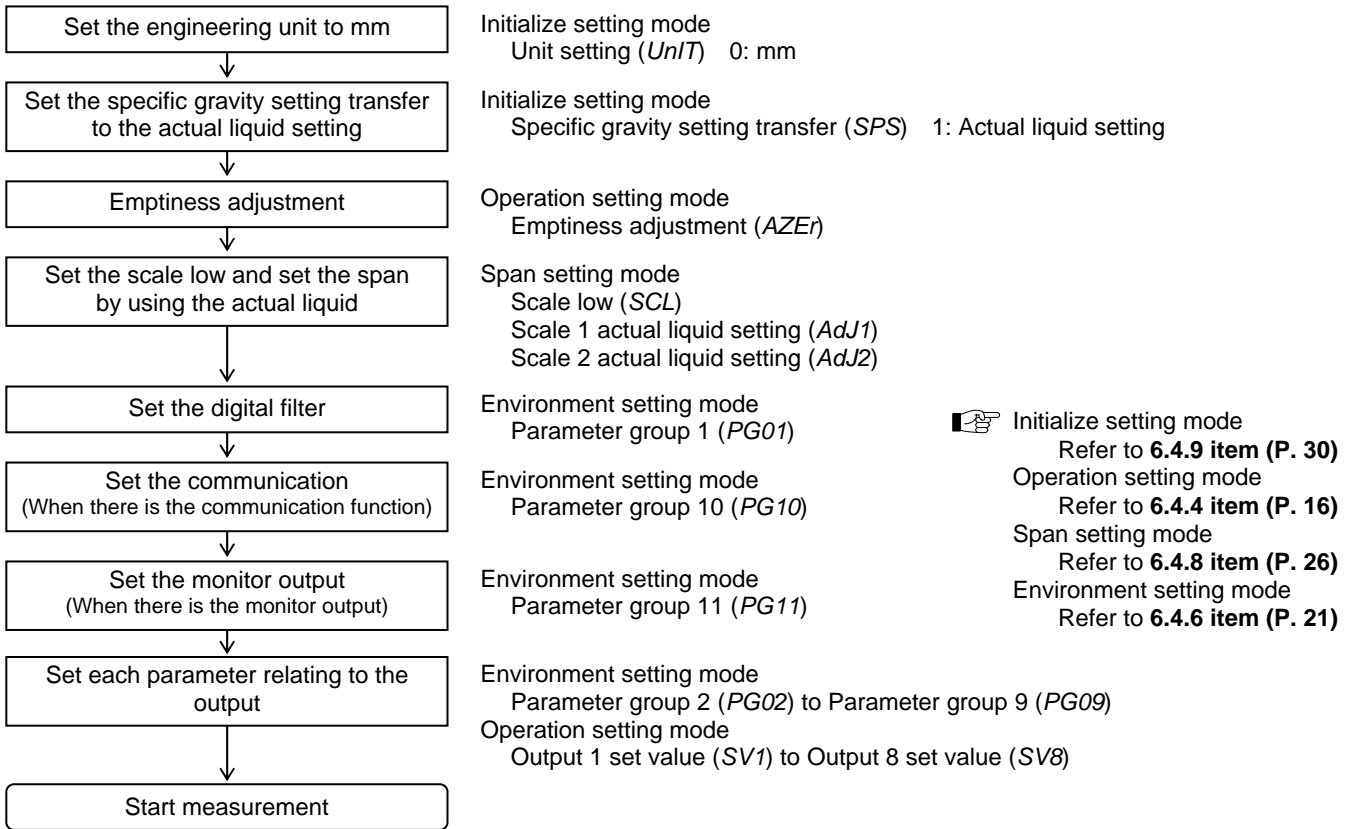

6.3.2 Level is measured in the unit of %

■ When the specific gravity is known

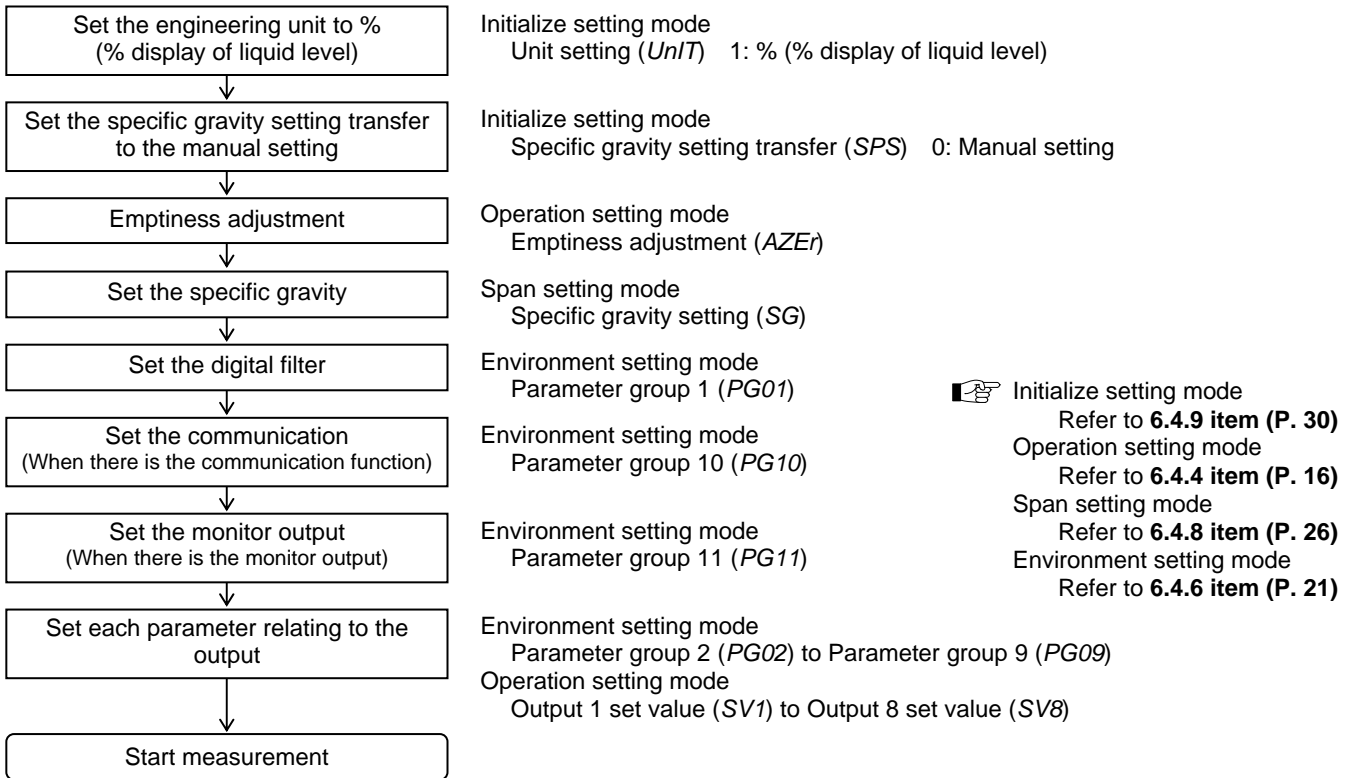

■ When the specific gravity is unknown



When setting the span by using the actual liquid whose specific gravity is unknown, leave a space between scale 1 actual liquid setting and scale 2 actual liquid setting as wide as possible within the measuring range (which may differ depending on the height of the tank used). The narrower the span, the larger the error of height (or volume) out of the measuring range. This setting is possible while the liquid is being charged or discharged.

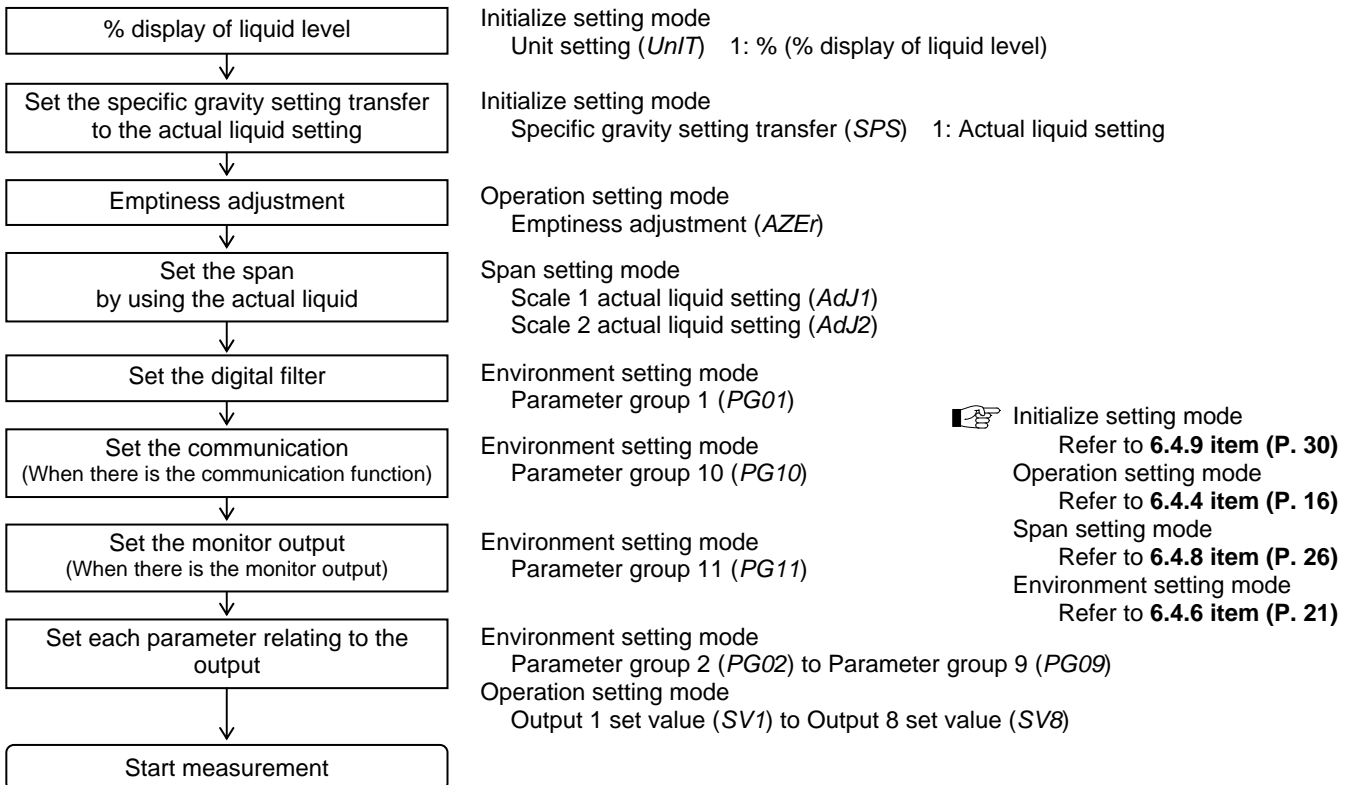

6.3.3 Measured in the unit of mL or L

■ When the specific gravity is known

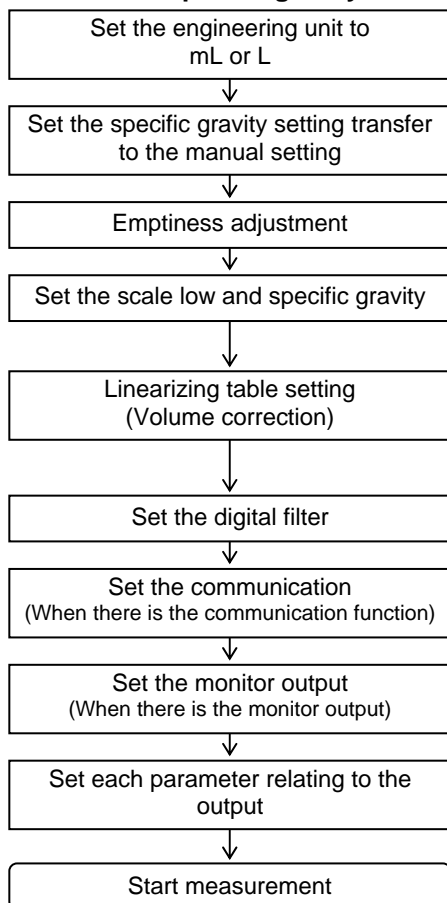

- Initialize setting mode
Unit setting (*UnIT*) 3: L or 4: mL
 - Initialize setting mode
Specific gravity setting transfer (*SPS*) 0: Manual setting
 - Operation setting mode
Emptiness adjustment (*AZE_r*)
 - Span setting mode
Scale low (*SCL*)
Specific gravity setting (*SG*)
 - Linearizing table setting mode
Decimal point position selection (*PG_{dp}*)
Number of linearizing table setting (*LInT*)
Linearizing table setting 0 (*Tb00*) to Linearizing table setting 10 (*Tb10*)
 - Environment setting mode
Parameter group 1 (*PG01*)
 - Environment setting mode
Parameter group 10 (*PG10*)
 - Environment setting mode
Parameter group 11 (*PG11*)
 - Environment setting mode
Parameter group 2 (*PG02*) to Parameter group 9 (*PG09*)
 - Operation setting mode
Output 1 set value (*SV1*) to Output 8 set value (*SV8*)
- Initialize setting mode
Refer to 6.4.9 item (P. 30)
- Operation setting mode
Refer to 6.4.4 item (P. 16)
- Span setting mode
Refer to 6.4.8 item (P. 26)
- Linearizing table setting mode
Refer to 6.4.5 item (P. 19)
- Environment setting mode
Refer to 6.4.6 item (P. 21)

■ When the specific gravity is unknown

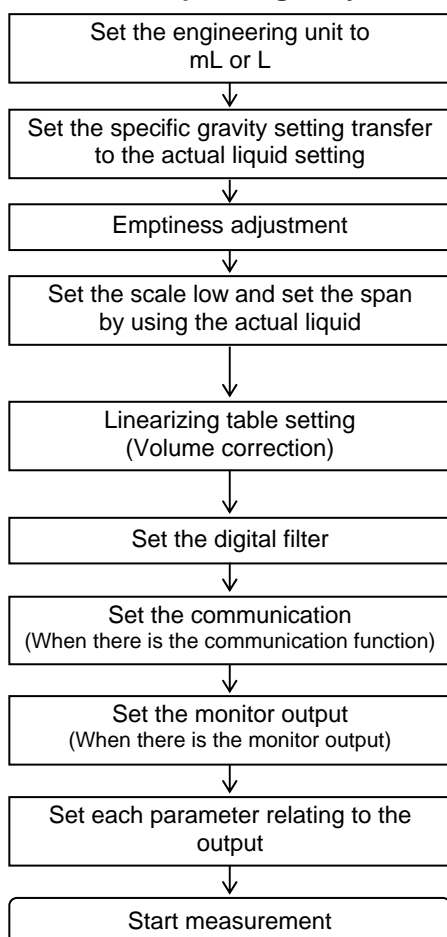

- Initialize setting mode
Unit setting (*UnIT*)
3: L or 4: mL
 - Initialize setting mode
Specific gravity setting transfer (*SPS*)
1: Actual liquid setting
 - Operation setting mode
Emptiness adjustment (*AZE_r*)
 - Span setting mode
Scale low (*SCL*)
Scale 1 actual liquid setting (*AdJ1*)
Scale 2 actual liquid setting (*AdJ2*)
 - Linearizing table setting mode
Decimal point position selection (*PG_{dp}*)
Number of linearizing table setting (*LInT*)
Linearizing table setting 0 (*Tb00*) to Linearizing table setting 10 (*Tb10*)
 - Environment setting mode
Parameter group 1 (*PG01*)
 - Environment setting mode
Parameter group 10 (*PG10*)
 - Environment setting mode
Parameter group 11 (*PG11*)
 - Environment setting mode
Parameter group 2 (*PG02*) to Parameter group 9 (*PG09*)
 - Operation setting mode
Output 1 set value (*SV1*) to Output 8 set value (*SV8*)
- When setting the span by using the actual liquid whose specific gravity is unknown, leave a space between scale 1 actual liquid setting and scale 2 actual liquid setting as wide as possible within the measuring range (which may differ depending on the height of the tank used). The narrower the span, the larger the error of height (or volume) out of the measuring range. This setting is possible while the liquid is being charged or discharged.**
- Initialize setting mode
Refer to 6.4.9 item (P. 30)
- Operation setting mode
Refer to 6.4.4 item (P. 16)
- Span setting mode
Refer to 6.4.8 item (P. 26)
- Linearizing table setting mode
Refer to 6.4.5 item (P. 19)
- Environment setting mode
Refer to 6.4.6 item (P. 21)

6.3.4 Pressure is measured in the unit of %

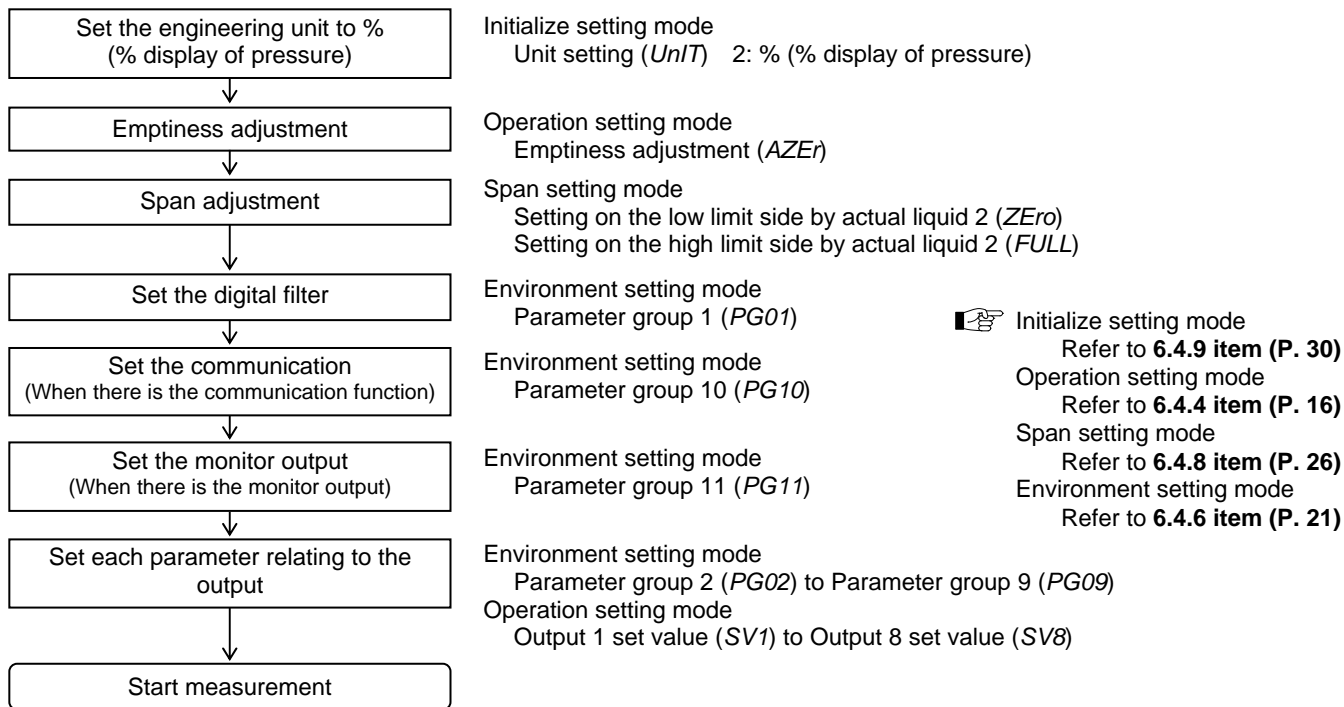

6.3.5 Measured in the unit of Pa or kPa

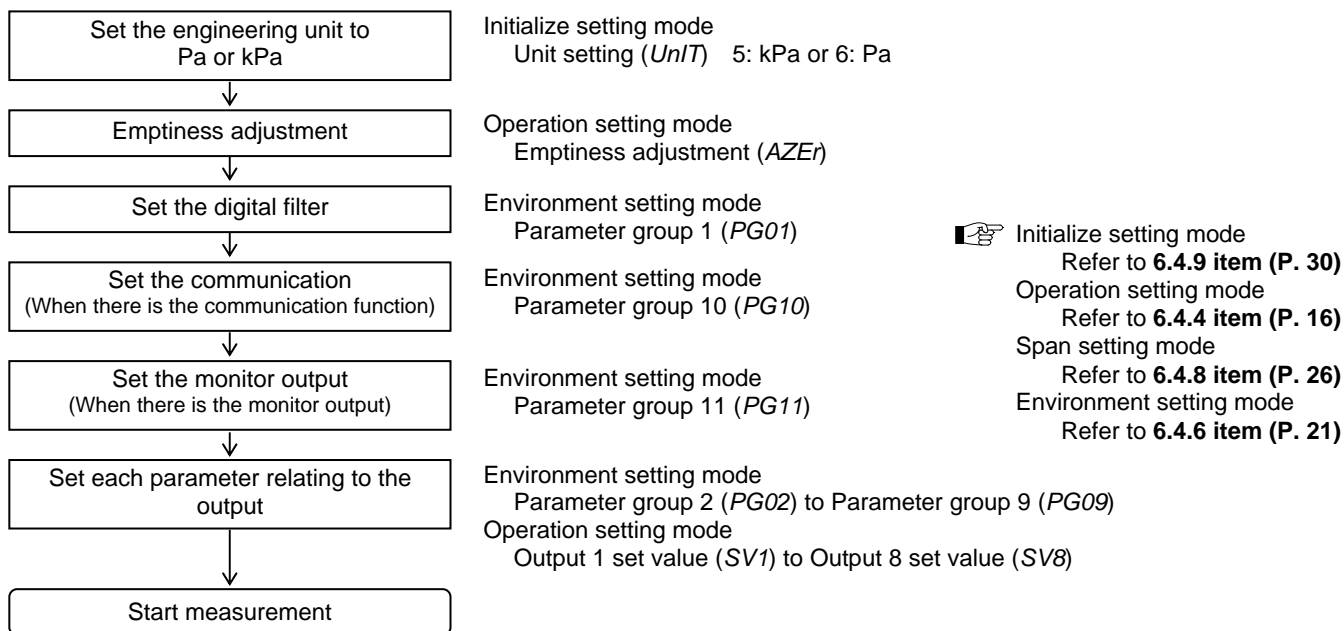

6.4 Detail of Each Mode

This section describes content of a parameter of each mode.

☞ For the operating procedure depending on the engineering unit used, refer to the **6.3 Operating Procedure (P. 10)**.

6.4.1 PV display mode

Display measured value on the Measured value (PV) display unit.

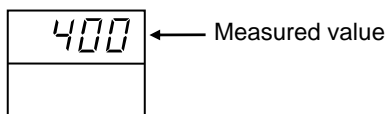

6.4.2 Operation monitor mode

This is the mode used for the operator to set the action or output of the instrument. The following parameter symbols are displayed one by one every time the SHIFT key is pressed.

■ Display flowchart

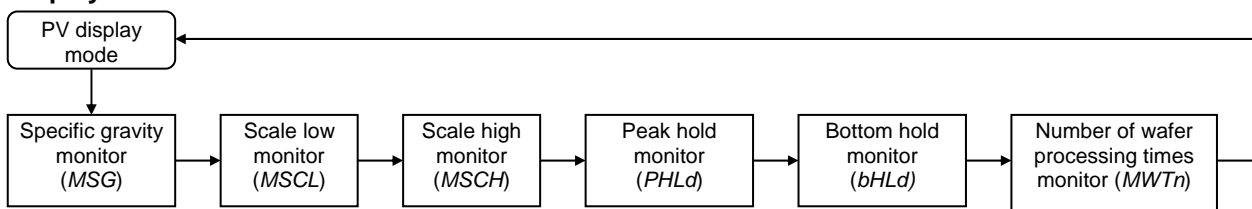

📖 Explaining the arrow mark → : Press the SHIFT key.

■ Operation monitor mode parameter list

| Symbol | Name | Range | Description |
|--------|--|---|--|
| (MSG) | Specific gravity monitor | 0.800 to 2.500 | Use to display the specific gravity. |
| (MSCL) | Scale low monitor | Scale low to Scale high | Use to display the scale low value. |
| (MSCH) | Scale high monitor | Scale low to Scale high | Use to display the scale high value. |
| (PHLd) | Peak hold monitor | Scale low to Scale high | Use to display the maximum value of measured value. |
| (bHLd) | Bottom hold monitor | Scale low to Scale high | Use to display the minimum value of measured value. |
| (MWTn) | Number of wafer processing times monitor | 1 to Number of wafer processing times setting | Use to display the number of wafer processing times. Displayed when the specific gravity correction function is provided. |

6.4.3 Amount of emptiness correction monitor mode

This is the mode used to check the amount of emptiness correction.

■ Display flowchart

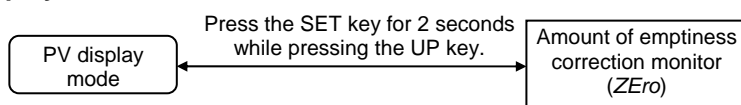

| Symbol | Name | Range | Description |
|--------|--|------------------------|--|
| (ZEro) | Amount of emptiness correction monitor | -5.00 to +5.00 of span | Use to display the amount of emptiness correction. |

6.4.4 Operation setting mode

This is the mode used for the operator to set general set values such as each output set value, etc. There are two methods of setting the liquid level of activating the output: manual level setting and level setting by actual liquid.

■ Display flowchart

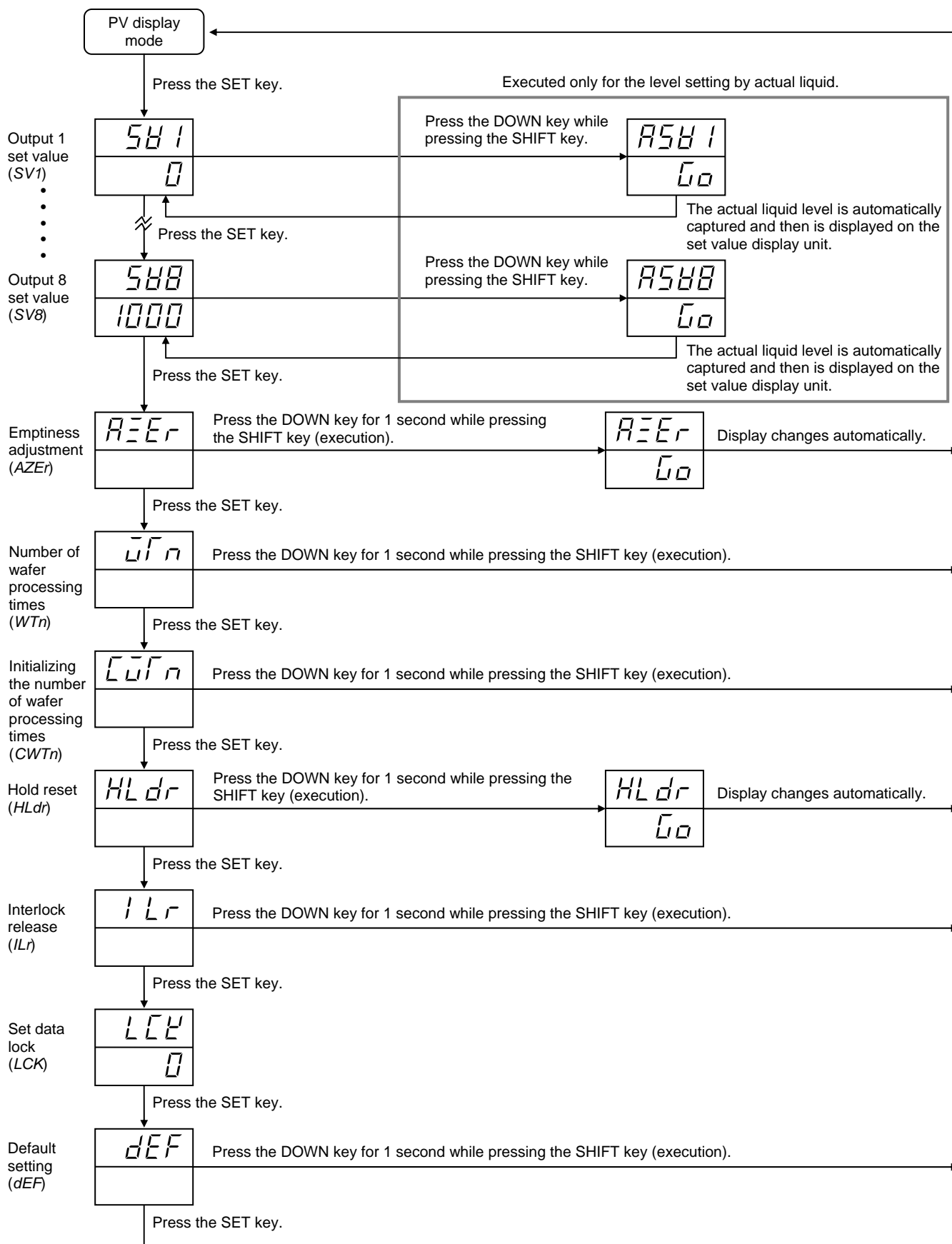

There are parameters which are not displayed depending on the specification.

Output setting by actual liquid:

Fill the actual liquid in the tank up to the liquid level to be output, then press the DOWN key while pressing the SHIFT key. Thus, the liquid level at that time is captured and that level becomes the output set value. It is possible to activate the output without fail at the level where it needs to be activated.

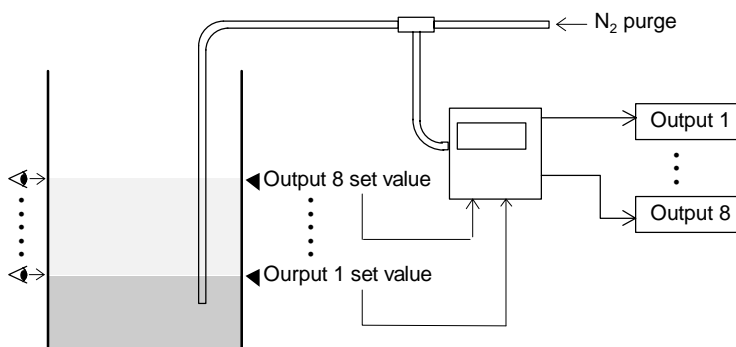

Emptiness adjustment:

If the emptiness adjustment is conducted with the end of the measuring tube opened to the atmosphere, the offset occurring in this instrument can be cancelled.



- When applying back pressure, use nitrogen gas of high purity which does not contaminate the liquid. When problem in particular does not have liquid pollution by purge gas, use air or the nitrogen gas which removed garbage and oil content of 0.3 μm greater or equal.
- Use the back pressure purge gas at a pressure of 20 ± 1 kPa and a flow rate of 50 ± 5 mL/min. If a pressure of more than 21 kPa is directly applied to the LE100, the instrument may fail.
- Do not pressurize the measuring tank.
- Measure only one tank using one set of the LE100.

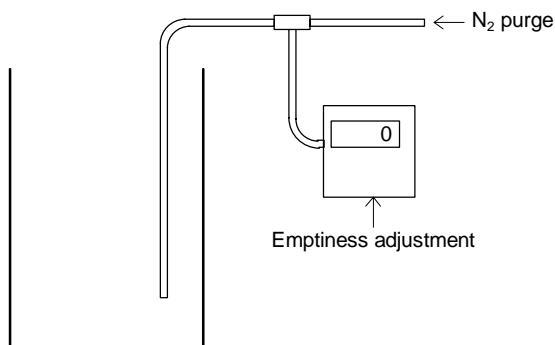

■ Operation setting mode parameter list

#1: Factory set value

| Symbol | Name | Range | Description | #1 |
|--|--|--|--|------------------|
| <p>581 (SV1) ⋮ 588 (SV8)</p> | <p>Output 1 set value ⋮ Output 8 set value</p> | Scale low to Scale high | Use to set the liquid level to activate output. Displayed only when the output action is other than OFF. Output 7 set value and Output 8 set value are displayed when the number of output points is 8. | Input range high |
| <p>AZER (AZEr)</p> | Emptiness adjustment | — | The emptiness adjustment is conducted. Executed when the DOWN key is pressed for 1 second while pressing the SHIFT key. | — |
| <p>WTn (WTn)</p> | Number of wafer processing times | — | The number of wafer processing times is measured. Displayed when the specific gravity correction function is provided. Executed when the DOWN key is pressed for 1 second while pressing the SHIFT key. | — |
| <p>CWTn (CWTn)</p> | Initializing the number of wafer processing times | — | Use to set the number of wafer processing times to 0. Displayed when the specific gravity correction function is provided. Executed when the DOWN key is pressed for 1 second while pressing the SHIFT key. | — |
| <p>HLdr (HLdr)</p> | Hold reset | — | The peak and bottom hold functions are reset. Executed when the DOWN key is pressed for 1 second while pressing the SHIFT key. | — |
| <p>ILr (ILr)</p> | Interlock release | — | The interlock is released. Executed when the DOWN key is pressed for 1 second while pressing the SHIFT key. | — |
| <p>LCK (LCK)</p> | Set data lock | <p>0: Set data lock not provided. 1: Only output set value can be set. 2: All parameter cannot be set.</p> | Use to set the level which enables set data lock. | 0 |
| <p>dEF (dEF)</p> | Default setting | — | Returned to the factory set value of each parameter. Executed when the DOWN key is pressed for 1 second while pressing the SHIFT key. | — |

6.4.5 Linearizing table setting mode

This is the mode used to set the liquid volume corresponding to the liquid level. Displayed when the unit is set to “L” or “mL.”

■ Display flowchart

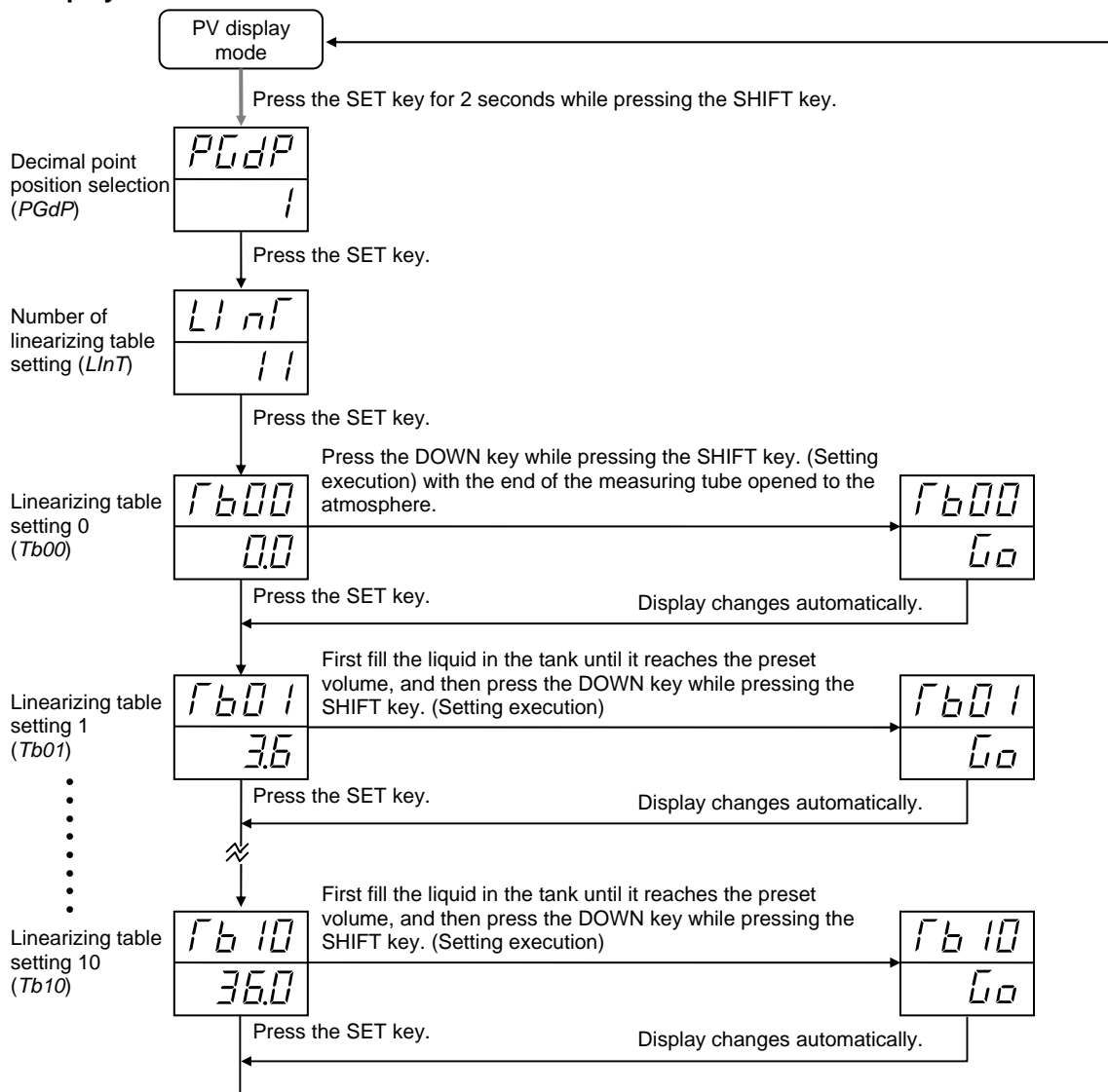

There are parameters which are not displayed depending on the specification.

Volume correction (Linearizing table):

Set the liquid volume corresponding to the height of the liquid in the tank used in linearizing table setting mode. For a tank having any shape in which there is no linear relationship between changes in liquid height and volume, more accurate liquid volume measurement can be performed by setting the volume at the corresponding point of inflection.

The linearizing table up to 11 liquid levels can be set.

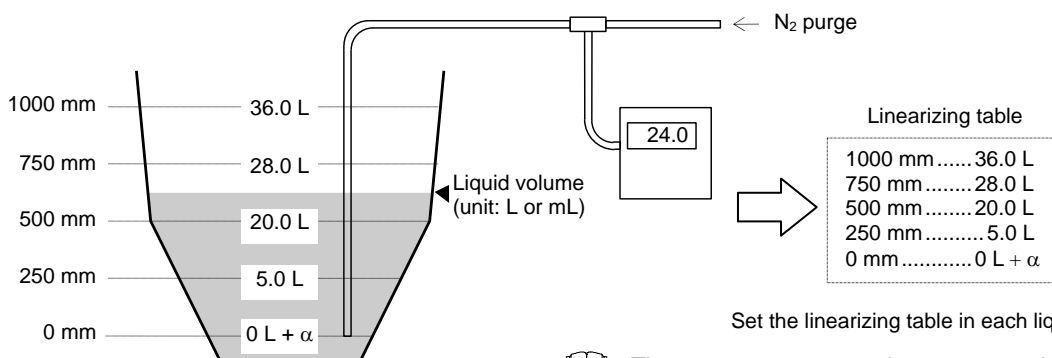

When the table of up to 5 liquid levels is set.

Set the linearizing table in each liquid level.







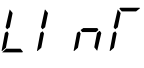

The accuracy may not be guaranteed under any of the following conditions.

- When the setting is not made at the point of inflection of the tank.
- When the display volume exceeding 4.4 % of full scale was set for a height change of 1 mm.

■ Linearizing table setting mode parameter list

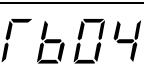
#1: Factory set value

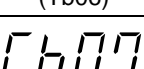
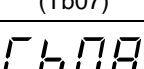
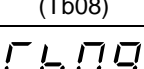
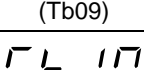
| Symbol | Name | Range | Description | #1 |
|---|-------------------------------------|---|--|------|
|  (PGdP) | Decimal point position selection | 0: No decimal place 1: One decimal place 2: Two decimal places 3: Three decimal places | Use to set the position of the decimal point for the volume. | 1 |
|  (LInT) | Number of linearizing table setting | 2 to 11 | Use to set the number of linearizing table to be created. | 11 |
|  (Tb00) | Linearizing table setting 0 | Scale low to Scale high | Use to set the liquid volume corresponding to the liquid level at the first point (minimum value). | 0.0 |
|  (Tb01) | Linearizing table setting 1 | Linearizing table setting 0 to Scale high | Use to set the liquid volume corresponding to the liquid level at the second point. | 3.6 |
|  (Tb02) | Linearizing table setting 2 | Linearizing table setting 1 to Scale high | Use to set the liquid volume corresponding to the liquid level at the third point. | 7.2 |
|  (Tb03) | Linearizing table setting 3 | Linearizing table setting 2 to Scale high | Use to set the liquid volume corresponding to the liquid level at the fourth point. | 10.8 |
|  (Tb04) | Linearizing table setting 4 | Linearizing table setting 3 to Scale high | Use to set the liquid volume corresponding to the liquid level at the fifth point. | 14.4 |
|  (Tb05) | Linearizing table setting 5 | Linearizing table setting 4 to Scale high | Use to set the liquid volume corresponding to the liquid level at the sixth point. | 18.0 |
|  (Tb06) | Linearizing table setting 6 | Linearizing table setting 5 to Scale high | Use to set the liquid volume corresponding to the liquid level at the seventh point. | 21.6 |
|  (Tb07) | Linearizing table setting 7 | Linearizing table setting 6 to Scale high | Use to set the liquid volume corresponding to the liquid level at the eighth point. | 25.2 |
|  (Tb08) | Linearizing table setting 8 | Linearizing table setting 7 to Scale high | Use to set the liquid volume corresponding to the liquid level at the ninth point. | 28.8 |
|  (Tb09) | Linearizing table setting 9 | Linearizing table setting 8 to Scale high | Use to set the liquid volume corresponding to the liquid level at the tenth point. | 32.4 |
|  (Tb10) | Linearizing table setting 10 | Linearizing table setting 9 to Scale high | Use to set the liquid volume corresponding to the liquid level at the eleventh point. | 36.0 |



The position of the decimal point for volume display differs depending on its selection.



The scale high differs depending on the position of the decimal point selection.

- No digit below decimal point..... 360 (“L” or “mL”)
- 1 digit below decimal point.....36.0 (“L” or “mL”)
- 2 digits below decimal point3.60 (“L” or “mL”)
- 3 digits below decimal point0.360 (“L” or “mL”)

6.4.6 Environment setting mode

This is the mode used to set the environment of the instrument used such as the output function activation setting, etc.

■ Display flowchart

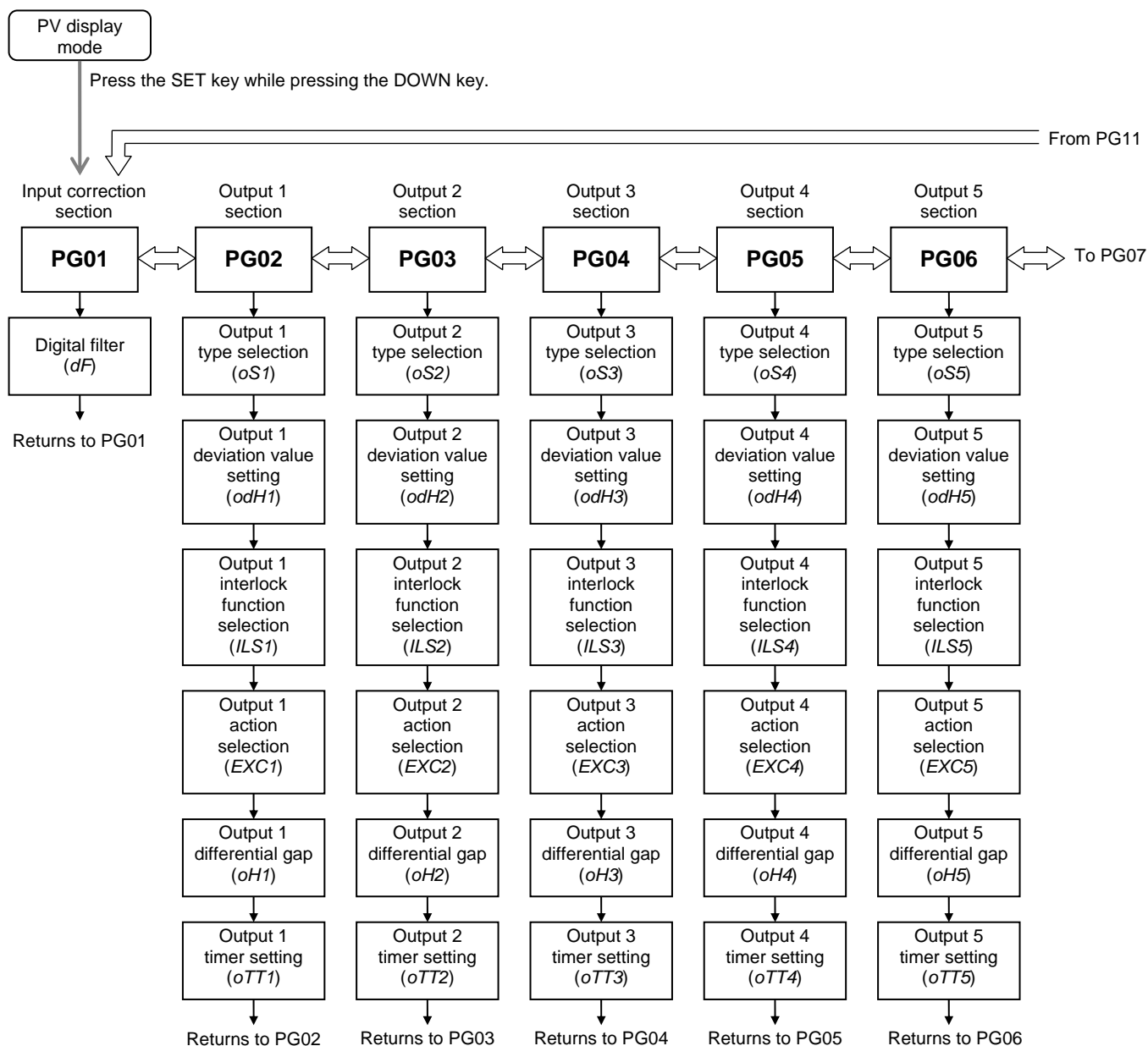

Explaining the arrow mark.



: Press the UP key or DOWN key.



: Press the SET key.



PG: Means Parameter Group



There are parameters which are not displayed depending on the specification.



To return to the PV display mode, press the SET key while pressing the DOWN key.

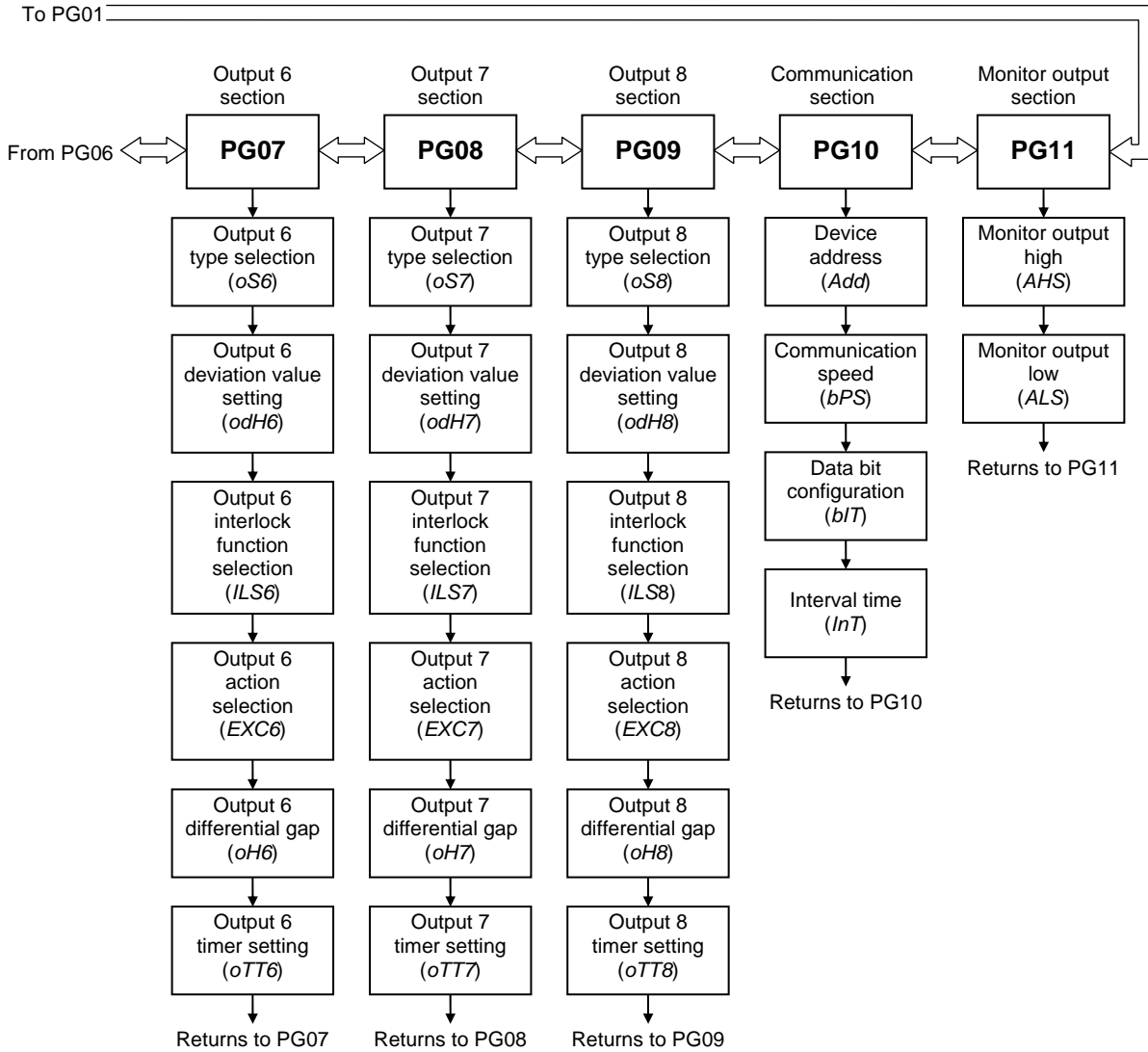

■ Environment setting mode parameter list

Input correction section [PG01]

#1: Factory set value

| Symbol | Name | Range | Description | #1 |
|-----------------------|-------------------|----------------------------|---|----|
| <i>PG01</i> (PG01) | Parameter group 1 | — | This is the first parameter symbol of parameter group 1. In addition, it is displayed first when the instrument is set to the environment setting mode. | — |
| <i>df</i> (dF) | Digital filter | 0: OFF 1 to 100 seconds | In order to lessen the effect of measuring liquid fluctuations (waves) by purge gas, set the time of the first order lag filter. | 3 |

Output 1 section [PG02] to Output 8 section [PG09]





Parameters relating to Output 7 [PG08] and Output 8 [PG09] are displayed when the number of output points is 8.

#1: Factory set value

| Symbol | Name | Range | Description | #1 |
|---|---|---|---|----|
| <i>PG02</i> (PG02) ⋮ <i>PG09</i> (PG09) | Parameter group 2 ⋮ Parameter group 9 | — | This is the first parameter symbol of parameter group. | — |
| <i>o51</i> (oS1) ⋮ <i>o58</i> (oS8) | Output 1 type selection ⋮ Output 8 type selection | 0: OFF 1: Process high output 2: Process low output 3: Deviation high output 4: Deviation low output | Use to select the output type. The high limit or low limit deviation output can be selected only when the engineering unit is set to mm. | 1 |
| <i>odH1</i> (odH1) ⋮ <i>odH8</i> (odH8) | Output 1 deviation value setting ⋮ Output 8 deviation value setting | −50 to +50 mm | Use to set the deviation value for output. Displayed when the engineering unit is set to mm and the output is of the high limit or low limit deviation type. | 0 |
| <i>1LS1</i> (ILS1) ⋮ <i>1LS8</i> (ILS8) | Output 1 interlock function selection ⋮ Output 8 interlock function selection | 0: Without interlock function 1: With interlock function | Use to set the presence or absence of the interlock function for output. The interlock function is used to hold the output ON state even if the measured value is out of the output ON zone after its entry into the output ON zone once. | 0 |
| <i>EYC1</i> (EXC1) ⋮ <i>EYC8</i> (EXC8) | Output 1 action selection ⋮ Output 8 action selection | 0: Transistor turned on in the output activating state 1: Transistor turned off in the output activating state | Use to select the transistor status (on or off) in the Output activating state (when the output lamp lights). The transistor status (on or off) is selected in the Output activating state (when the output lamp lights). | 0 |

Continued on the next page.

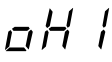
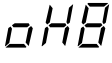

#1: Factory set value

| Symbol | Name | Range | Description | #1 |
|---|---|-----------------------|--|-----|
|  (oH1) ⋮  (oH8) | Output 1 differential gap ⋮ Output 8 differential gap | 0.0 to 10.0 % of span | Use to set the output differential gap. | 0.3 |
|  (oTT1) ⋮  (oTT8) | Output 1 timer setting ⋮ Output 8 timer setting | 0 to 600 seconds | Use to set the time until output is turned on after measured value enters output area. | 0 |

Communication section [PG10]

 Displayed when there is the communication function.

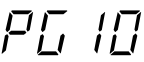
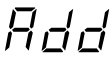
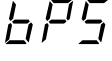
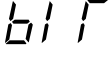
#1: Factory set value

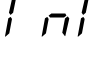
| Symbol | Name | Range | Description | #1 |
|--|------------------------|--|--|----|
|  (PG10) | Parameter group 10 | — | This is the first parameter symbol of parameter group 10. | — |
|  (Add) | Device address | 0 to 99 | Use to set device address of this instrument. | 0 |
|  (bPS) | Communication speed | 0: 2400 bps 1: 4800 bps 2: 9600 bps 3: 19200 bps | Use to select the communication speeds. | 2 |
|  (bit) | Data bit configuration | 0 to 5  Refer to Data Bit Configuration Table. | Use to select the data bit configuration during communication. | 0 |
|  (InT) | Interval time | 0 to 250 ms | Use to set the interval time to match timing during data send and receive. | 5 |

Data Bit Configuration Table

| Set value | Data bit | Parity bit | Stop bit |
|-----------|----------|------------|----------|
| 0 | 8 | Without | 1 |
| 1 | 8 | Without | 2 |
| 2 | 7 | Even | 1 |
| 3 | 7 | Even | 2 |
| 4 | 7 | Odd | 1 |
| 5 | 7 | Odd | 2 |

Monitor output section [PG11]

 Displayed when there is the monitor output function.

#1: Factory set value

| Symbol | Name | Range | Description | #1 |
|-----------------------|---------------------|----------------------------------|---|------|
| PG11 (PG11) | Parameter group 11 | — | This is the first parameter symbol of parameter group 11. | — |
| AHS (AHS) | Monitor output high | Monitor output low to Scale high | Sets high limit of the monitor output range. | 1000 |
| ALS (ALS) | Monitor output low | Scale low to Monitor output high | Sets low limit of the monitor output range. | 0 |

6.4.7 Specific gravity correction setting mode

This is the mode used to set the parameter to conduct the correction caused by changes in the specific gravity of chemicals resulting from changes of the number of wafer processing times. Displayed when the engineering unit is set to mm and the specific gravity correction functions is provided. The following parameter symbols are displayed one by one every time the SET key is pressed.

■ Display flowchart

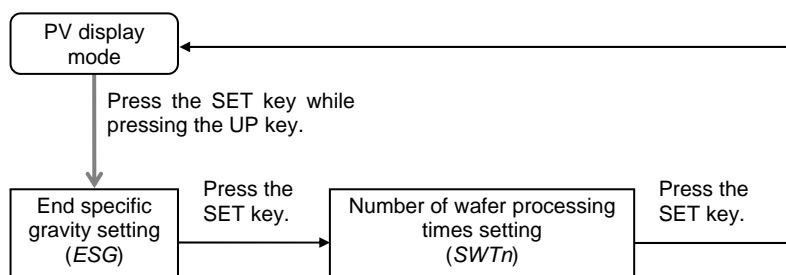

■ Specific gravity correction setting mode parameter list

#1: Factory set value

| Symbol | Name | Range | Description | #1 |
|-----------------------|--|----------------|--|-------|
| ESG (ESG) | End specific gravity setting | 0.800 to 2.500 | Use to set the end specific gravity setting for specific gravity correction. | 1.000 |
| SWTn (SWTn) | Number of wafer processing times setting | 1 to 20 | The number of wafer processing times to result in the final specific gravity is set. | 10 |

6.4.8 Span setting mode

This is the mode used to set the span corresponding to the engineering unit used. The method of span setting differs depending on the engineering unit used and the setting selection of specific gravity (manual setting or actual liquid setting).

| Unit setting (<i>Unit</i>) | Specific gravity setting transfer (<i>SPS</i>) | Span setting |
|--|--|--------------------------------------|
| mm, % (% display of liquid level), L, mL | Manual setting | (1) Span setting by specific gravity |
| mm, % (% display of liquid level), L, mL | Actual liquid setting | (2) Span setting by actual liquid |
| % (% display of pressure) | — | (3) Span adjustment |

For the Unit setting (*Unit*) and Specific gravity setting transfer (*SPS*), refer to the **6.4.9 Initialize setting mode (P. 30)**.

(1) Span setting by specific gravity

Set the span by specific gravity. Set the Scale low and Specific gravity setting in Span setting mode.

■ Display flowchart

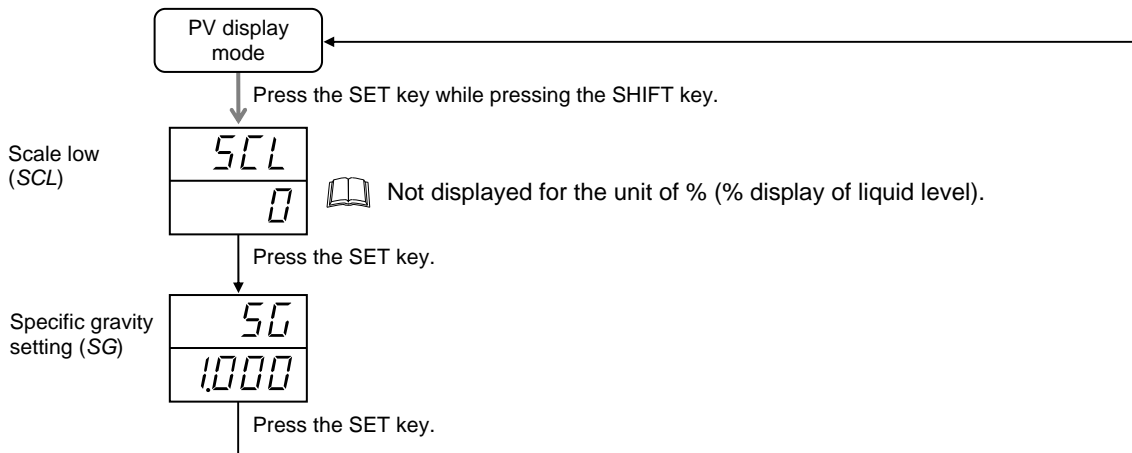

■ Setting procedure

The scale high is automatically calculated by setting the scale low (unit: mm) and specific gravity of the liquid to display the liquid level. The scale low is set in height (0 to 50 mm) regardless of the engineering unit used. In addition, if the unit of % (% display of liquid level) is used, the scale low is not set as the end of the measuring tube corresponds to 0 %.

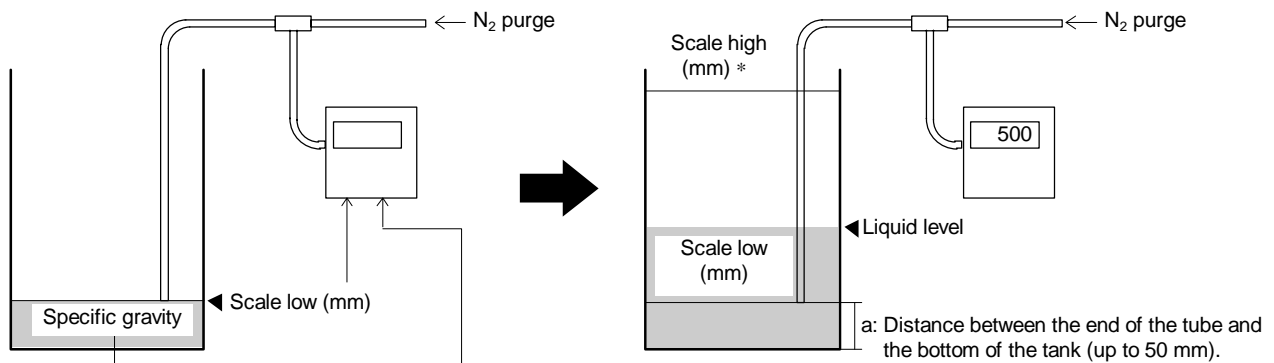

The pressure at each liquid level is measured in accordance with the pressure corresponding to the scale low and the gain called "specific gravity" to calculate the liquid level.

* Scale high: High limit which can be measured by the LE100
(For a specific gravity of 1.0: Up to 1000 mm + a)

(2) Span setting by actual liquid

Set the span by actual liquid. Set Scale low, and adjust Scale 1 and Scale 2 actual liquid settings for obtaining the specific gravity of the liquid used in span setting mode.

■ Display flowchart

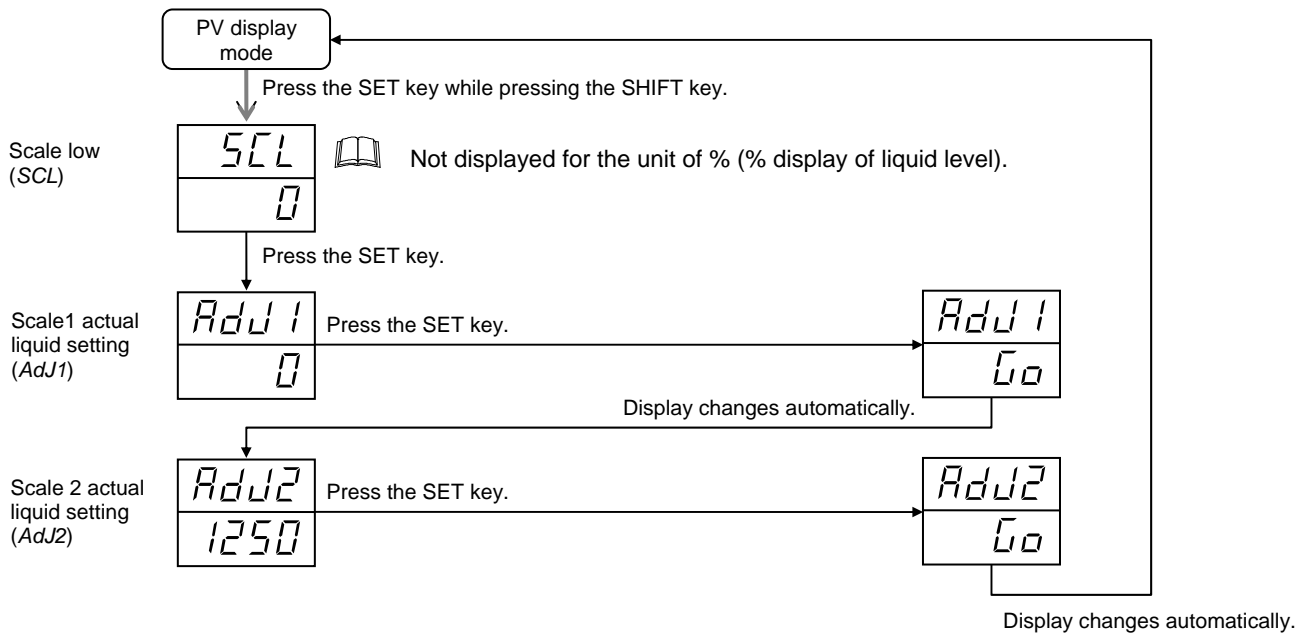

To return to the PV display mode before adjustment is performed, press the SET key while pressing the SHIFT key.

■ Setting procedure

The specific gravity is automatically calculated by freely setting the upper and lower liquid levels (unit: mm). The scale high is also automatically calculated by the scale low (unit: mm) and the specific gravity thus calculated. As a result, the liquid level is displayed.

The upper liquid level and the lower liquid level are set in height (unit: mm) regardless of the engineering unit used. In addition, if the unit of % (% display of liquid level) is used, the scale low is not set as the end of the measuring tube corresponds to 0 %.

When setting the span by using the actual liquid whose specific gravity is unknown, leave a space between scale 1 actual liquid setting and scale 2 actual liquid setting as wide as possible within the measuring range (which may differ depending on the height of the tank used). The narrower the span, the larger the error of height (or volume) out of the measuring range. This setting is possible while the liquid is being charged or discharged.

If the specific gravity of the liquid is changed, re-settings are required.

Scale 1 actual liquid setting (Adj1) set to 0 mm results in one-point correction.

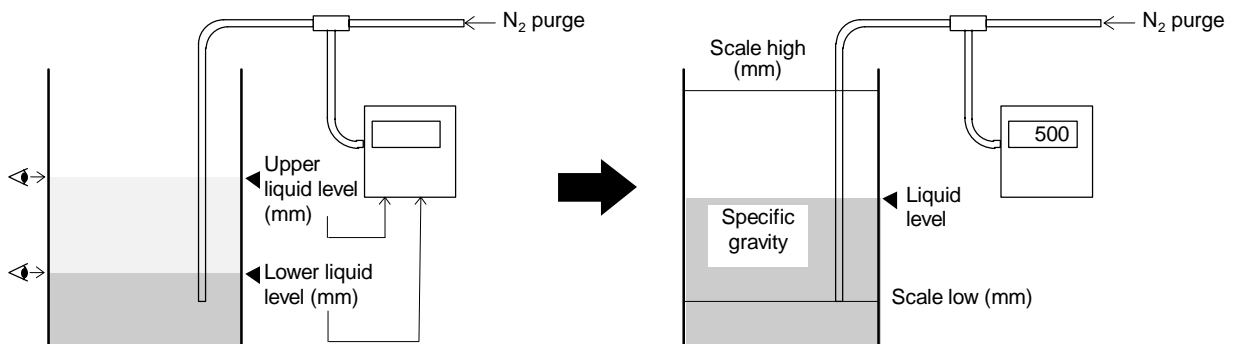

The liquid level is calculated by using the ratio of pressure to height and the height set on each of the upper and lower sides.

(3) Span adjustment

Adjust the span in Span setting mode. Pressing the SET key at each of the pressures set to the low limit (Setting on the low limit side by actual liquid 2) and high limit (Setting on the high limit side by actual liquid 2) automatically displays the level between them at a value of 0 to 100 %.

■ Display flowchart

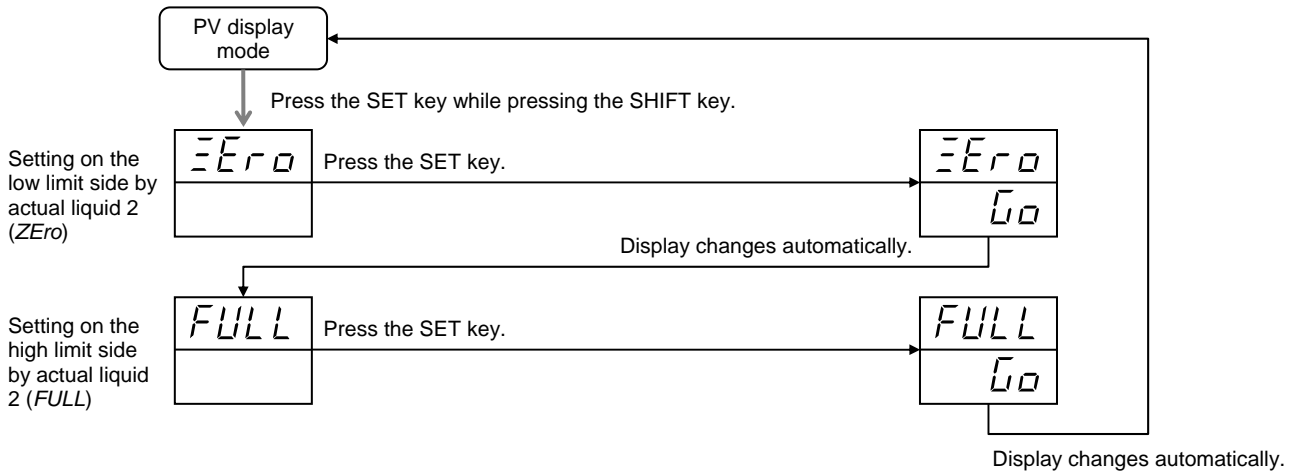

To return to the PV display mode before adjustment is performed, press the SET key while pressing the SHIFT key.

■ Setting procedure

If the specific gravity of the liquid is changed, re-settings are required.

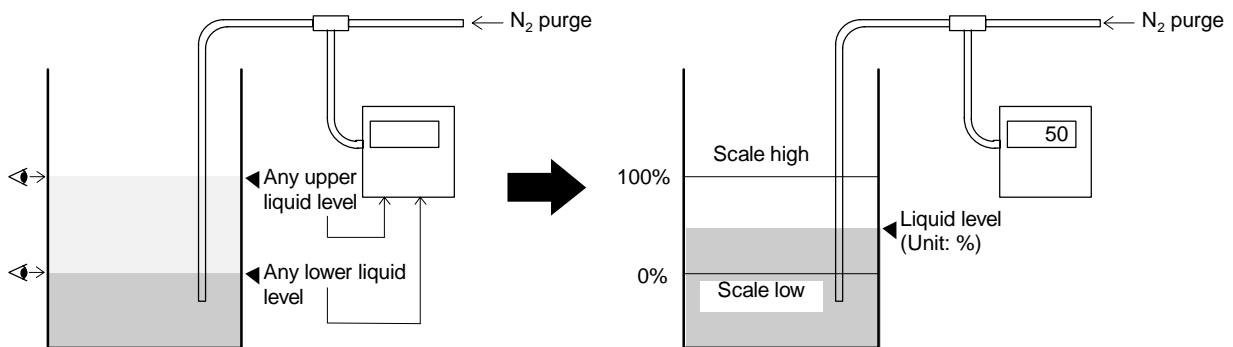

The pressures corresponding to the upper and lower liquid levels are converted to liquid levels of 0 and 100 % and then are displayed.

■ Span setting mode parameter list

#1: Factory set value

| Symbol | Name | Range | Description | #1 |
|-----------------------|---|----------------|---|-------|
| <i>SCL</i> (SCL) | Scale low | 0 to 50 mm | Use to set the scale low value. Set the distance between the end of the measuring tube and the bottom of the tank used. Displayed when the engineering unit is set to mm, L or mL. | 0 |
| <i>SG</i> (SG) | Specific gravity setting | 0.800 to 2.500 | Use to set the specific gravity. Displayed when the engineering unit is set to mm, % (% display of liquid level), L or mL, and the specific gravity setting transfer is changed to the manual setting. | 1.000 |
| <i>Adj1</i> (Adj1) | Scale 1 actual liquid setting | 0 to 1250 mm | Use to set the liquid level. Displayed when the engineering unit is set to mm, % (% display of liquid level), L or mL, and the specific gravity setting transfer is changed to the actual liquid setting. | 0 |
| <i>Adj2</i> (Adj2) | Scale 2 actual liquid setting | 1 to 1250 mm | Use to set the liquid level. Displayed when the engineering unit is set to mm, % (% display of liquid level), L or mL, and the specific gravity setting transfer is changed to the actual liquid setting. | 1250 |
| <i>ZERO</i> (ZEro) | Setting on the low limit side by actual liquid 2 | — | Any pressure displayed at 0 % is captured. Executed when the SET key is pressed. Displayed when the engineering unit is set to % (% display of pressure). | — |
| <i>FULL</i> (FULL) | Setting on the high limit side by actual liquid 2 | — | Any pressure displayed at 100 % is captured. Executed when the SET key is pressed. Displayed when the engineering unit is set to % (% display of pressure). | — |

6.4.9 Initialize setting mode

This is the mode used to set the initial value of the instrument such as the engineering unit, etc. The following parameter symbols are displayed one by one every time the SET key is pressed.

■ Display flowchart

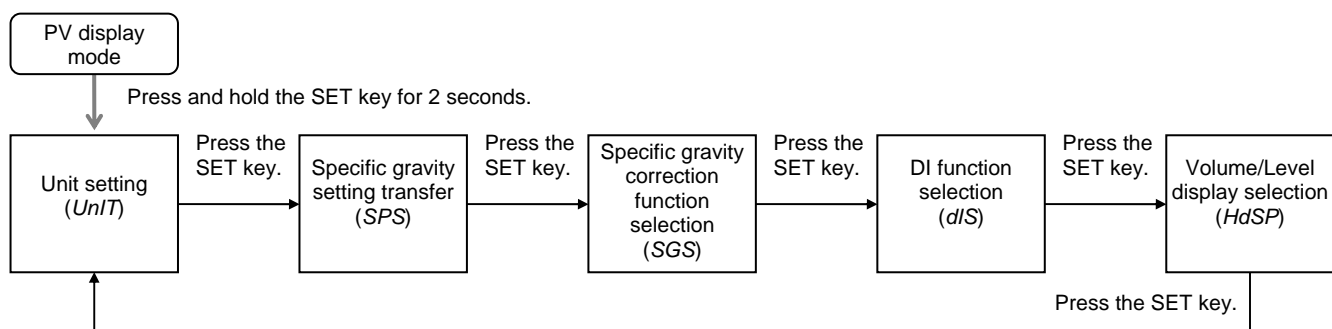

To return to the PV display mode, press and hold the SET key for 2 seconds.

■ Initialize setting mode parameter list

#1: Factory set value

| Symbol | Name | Range | Description | #1 |
|-----------------------|--|---|---|-----|
| <i>Unit</i> (Unit) | Unit setting | 0: mm 1: % (% display of liquid level) 2: % (% display of pressure) 3: L 4: mL 5: kPa 6: Pa | Use to set the engineering unit. Refer to Input Range Table. | 0 |
| <i>SPS</i> (SPS) | Specific gravity setting transfer | 0: Manual setting 1: Actual liquid setting | The specific gravity setting method is selected. Displayed when the engineering unit is set to mm, % (% display of liquid level), L or mL. | 0 |
| <i>SGS</i> (SGS) | Specific gravity correction function selection | 0: Without specific gravity correction function 1: With specific gravity correction function | Use to set the presence or absence of the specific gravity correction function for number of wafer processing times setting. Displayed when the engineering unit is set to mm, and the specific gravity setting transfer is changed to the manual setting. | 0 |
| <i>dIS</i> (dIS) | DI function selection | 0: For conducting the emptiness adjustment 1: For counting the number of wafer processing times | Use to select the DI function. Displayed when the instrument is provided with the contact input and specific gravity correction function. | 0 |
| <i>HdSP</i> (HdSP) | Volume/Level display selection | OFF: Volume display ON: Level display | It is selected whether the volume is displayed as L/mL (volume) or mm (level). Displayed when the engineering unit is set to L or mL. | OFF |

Input Range Table

| Unit setting | Unit | Range | Notes |
|--------------|------|--------------|--|
| 0 | mm | 0 to 1250 | The high limit is determined by the specific gravity setting. At specific gravity 0.8: 0 to 1250 mm, At specific gravity 1: 0 to 1000 mm, At specific gravity 2.5: 0 to 400 mm |
| 1 | % | 0.0 to 100.0 | % display of liquid level. |
| 2 | % | 0.0 to 100.0 | % display of pressure. |
| 3 | L | 0 to 360 | The decimal point position depends on the decimal point position selection. |
| 4 | mL | 0 to 360 | The decimal point position depends on the decimal point position selection. |
| 5 | kPa | 0 to 9.807 | — |
| 6 | Pa | 0 to 9807 | — |

7. DISPLAY AT ERROR OCCURRENCE

■ Over-scale and Underscale

| Display | Details | Solution |
|------------------------------|---|--|
| Measured value [Flashing] | Measured value exceeds the scale range. | <ul style="list-style-type: none"> • Check input pressure. • Check measured tube. • Check measured tube connection. |
| 0000 [Flashing] | Measured value is beyond the effective input range. | |
| UUUU [Flashing] | Measured value is below the effective input range. | |

■ Error display

In an error is detected by the self-diagnostic function, the Measured value (PV) display unit flashes *Err*, and the set value display unit shows the error code. If two or more errors occur simultaneously, the total summation of these error codes is displayed.

| Error code | Details | Possible cause | Solution |
|------------|--|--|---|
| 1 | Adjusted data destruction error | The SUM value of adjusted data differs from SUM. | Pressing the DOWN key while pressing the UP key eliminates the error. If an error occurs after the power is turned on again, please contact RKC sales office or the agent. |
| 2 | EEPROM data write error | Data written in the EEPROM does not match read data. | |
| 4 | EEPROM time out error | Data not writable in the EEPROM. | |
| 8 | Input capture hardware error | The input exceeded the capture range of the A/D converter in the instrument. | |
| 16 | Emptiness adjustment execution error | The result of emptiness adjustment execution exceeded $\pm 5\%$ of span. | |
| | | When the emptiness adjustment does not end in 10 seconds after its adjustment starts. | |
| 32 | Span setting by actual liquid error | The setting exceeded the input capture range. | |
| | | The specific gravity setting was out of the range from 0.800 to 2.500. | |
| | | The setting was out of the set value from 0 to 50 mm on the low limit side. | |
| | | Only the high limit side was executed. | |
| 64 | Span adjustment execution error | The input capture range when the span adjustment on the low limit side was executed was out of the range from 0 to 30 %. | |
| | | The input capture range when the span adjustment on the high limit side was executed was out of the range from 70 to 100 %. | |
| | | Only the span adjustment on the high limit side was executed. | |
| | | The input capture value for the span adjustment on the low limit side was below that for the span adjustment on the high limit side. | |
| 128 | Number of wafer processing times error | The wafer processing was executed exceeding the number of wafer processing times setting. | |
| 256 | Output setting by actual liquid error | The setting exceeded the input capture range. | |
| 512 | Linearizing table setting error | The setting exceeded the input capture range. | |

8. SPECIFICATIONS

■ Input

| | |
|------------------------------------|--|
| Number of input points: | 1 point |
| Input media: | Non corrosive gas |
| Input pressure range: | 0 to 9.807 kPa |
| Emptiness adjustment range: | ±5.0 % of span |
| Sampling cycle: | 0.2 seconds |
| Input digital filter: | First order lag digital filter Time constant: 0 to 100 seconds (0: Filter OFF) |

■ Display

| | |
|-------------------------------------|--------------------------------------|
| Measured value (PV) display: | 7-segment LED (4 digit, Green) |
| Set value display: | 7-segment LED (4 digit, Orange) |
| Output lamps: | LED (Green) OUT1 to OUT8 |
| Unit lamps: | LED (Green) kPa, Pa, mL, L, %, mm |

■ Settings

| | |
|------------------------|--|
| Setting method: | Interactive setting using front keys. |
| Unit setting: | height (mm), percentage (%), volume (L, mL) and pressure (kPa, Pa) |

■ Performance

| | |
|-------------------------------------|--|
| Repeatability: | ±0.3 % of span (Including display and setting) |
| Non linearity: | ±0.5 % of span |
| Temperature characteristics: | Zero output, ±0.04 % of span/°C Span output, ±0.04 % of span/°C |



All of the performance has a digital error of one digit.



Amount of long-term drift: ±0.3 % of span (for 6 months)

■ Output

| | |
|------------------------------------|---|
| Number of output points: | 6 points (Standard) or 8 points (Optional) |
| Output type: | Open collector output (sink type) <ul style="list-style-type: none">• Transistor turned on in the output activating state• Transistor turned off in the output activating state Any can be selected. |
| Load voltage: | 24 V DC (31.2 V DC max.) |
| Maximum load current: | 60 mA DC |
| Leak current when OFF: | 0.1 mA DC or less |
| Maximum voltage drop at ON: | 2.4 V DC or less (At a load current of 60 mA DC) |
| Output action: | Process high output, Process low output, Deviation high output, Deviation low output |
| Setting range: | Input scale low to Input scale high |
| Deviation value setting: | -50 to +50 mm |
| Differential gap: | 0.0 to 10.0 % of span |
| Additional function: | Timer setting: 0 to 600 seconds Interlock function |

■ Contact input (Optional)

| | |
|--------------------------------|--|
| Number of input points: | 1 point |
| Input type: | Dry contact input rated |
| | Resistance value at contact opens: 500 kΩ or more |
| | Resistance value at contact closed: 10 Ω or less |
| Function: | Emptiness adjustment Number of wafer processing times Any can be selected. |



The display span of height (mm), percentage (%) or volume (L or mL) corresponds to 9.807 kPa if pressure converted.



The span of the monitor output corresponds to 2.5 V.

■ Communication (Optional)

| | |
|--------------------------------|---|
| Interface: | Based on RS-485, EIA standard |
| Connection method: | 2-wire system, half-duplex multi-drop connection |
| Communication distance: | 1 km max. The maximum communication distance will be affected by the surrounding conditions. |
| Synchronous method: | Start/Stop synchronous type |
| Communication speed: | 2400 bps, 4800 bps, 9600 bps, 19200 bps |
| Protocol: | ANSI X3.28-1976 subcategories 2.5 and A4 Polling/Selecting type |
| Communication code: | ASCII 7-bit code |
| Termination resistor: | Externally connected |
| Maximum connections: | 32 instruments maximum including a host computer |

■ Monitor output (Optional)

| | |
|-----------------------------------|--|
| Number of output points: | 1 point |
| Output type: | 0.0 to 2.5 V DC |
| Allowable load resistance: | 1 kΩ or more |
| Output impedance: | 0.1 Ω or less |
| Output accuracy: | ±0.3 % of span |
| Output ripple: | ±0.1 % of span or 1 mV or less (resistive load) |
| Output resolution: | 10 bits or more |

■ Power

| | |
|------------------------------|---|
| Power supply voltage: | 21.6 to 26.4 V DC [Including power supply voltage variation], Rating: 24 V DC |
| Current consumption: | 130 mA max. (at 24 V DC) |

■ General specifications

| | |
|---------------------------------------|---|
| Insulation resistance: | Between output and case, 20 MΩ or more at 500 V DC Between power and case, 20 MΩ or more at 500 V DC |
| Withstand voltage: | Between output and case, 1 minute at 500V AC Between power and case, 1 minute at 500V AC |
| Power failure effect: | No influence is exerted upon the instrument for power failure of less than 30 ms. |
| Data backup: | Data backed up by EEPROM Number of write times: Approx. 100,000 times Data storage period: Approx. 10 years |
| Allowable ambient temperature: | 0 to 50 °C |
| Allowable ambient humidity: | 45 to 85 %RH (Non condensing) Absolute humidity: MAX.W.C 29 g/m ³ dry air at 101.3 kPa |
| Usage atmosphere: | There must be no corrosive gas and dust must not be excessive. |

■ Standard

| | |
|-------------------------|--|
| Safety standard: | UL: UL 61010-1 cUL: CAN/CSA-C22.2 No.61010-1 KEMA: EN61010-1 |
| CE making: | LVD: EN61010-1 EMC: EN61326-1 |

■ Mounting and structure

| | |
|-------------------------|------------------------------|
| Mounting method: | Panel mounting |
| Weight: | Approx. 150 g |
| Dimensions: | 48 (W) × 48 (H) × 100 (D) mm |

The first edition: OCT. 1999
The eighth edition: NOV. 2017 [IMQ00]

