

# Immersion

## MTO-3 Medium Weight Oil Applications

- 2-1/2" NPT Steel Screw Plug
- Steel Sheath Elements
- 15 W/in<sup>2</sup>
- 3 - 9 kW
- Without Thermostat
- 240 and 480 Volt, Three Phase
- General Purpose, Moisture Resistant/Explosion Resistant Terminal Enclosure or Moisture Resistant

E1 — Dimensions (Inches)

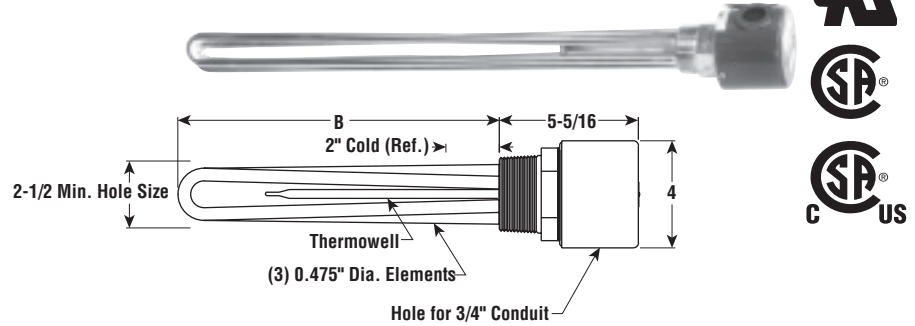

E2 — Dimensions (Inches)

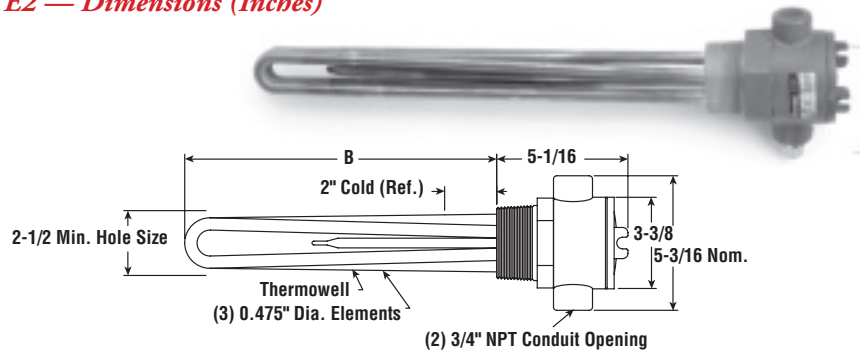

E4TP — Dimensions (Inches)

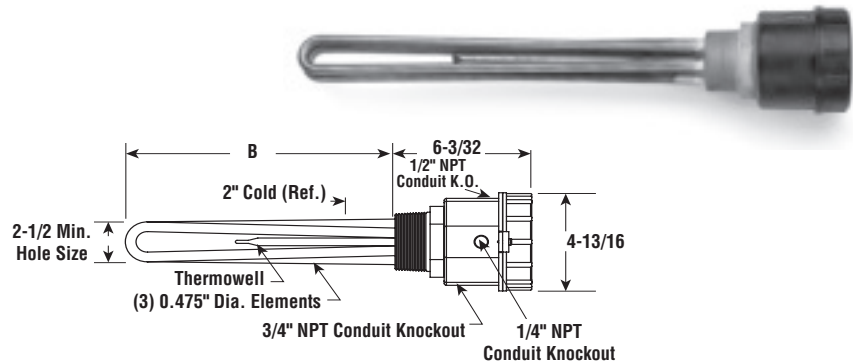

### Specifications and Ordering Information

|     |       |       |                   |           |             | E1 General Purpose <sup>1</sup> |       |        |            | E2 Moisture Resistant/<br>Explosion Resistant <sup>2</sup> |       |        |            | E4 Moisture Resistant |       |        |            |
|-----|-------|-------|-------------------|-----------|-------------|---------------------------------|-------|--------|------------|--|-------|--------|------------|-----------------------|-------|--------|------------|
| kW  | Volts | Phase | W/in <sup>2</sup> | No. Elem. | DIM B (In.) | Model                           | Stock | PCN    | Wt. (Lbs.) | Model  | Stock | PCN    | Wt. (Lbs.) | Model                 | Stock | PCN    | Wt. (Lbs.) |
| 3   | 240   | 3     | 15                | 3         | 24-3/8      | MTO-303                         | NS    | 324021 | 6          | MTO-303E2  | NS    | 324030 | 9          | MTO-303E4TP           | NS    | 064426 | 12         |
| 3   | 480   | 3     | 15                | 3         | 24-3/8      | MTO-303                         | NS    | 324048 | 6          | MTO-303E2  | NS    | 324056 | 9          | MTO-303E4TP           | NS    | 064434 | 12         |
| 4   | 240   | 3     | 15                | 3         | 32-1/4      | MTO-304                         | NS    | 324064 | 9          | MTO-304E2  | NS    | 324072 | 12         | MTO-304E4TP           | NS    | 064442 | 15         |
| 4   | 480   | 3     | 15                | 3         | 32-1/4      | MTO-304                         | NS    | 324080 | 9          | MTO-304E2  | NS    | 324099 | 12         | MTO-304E4TP           | NS    | 064450 | 15         |
| 5   | 240   | 3     | 15                | 3         | 39-3/4      | MTO-305                         | NS    | 324101 | 10         | MTO-305E2  | NS    | 324110 | 13         | MTO-305E4TP           | NS    | 064469 | 16         |
| 6   | 240   | 3     | 15                | 3         | 47-1/4      | MTO-306                         | NS    | 324128 | 11         | MTO-306E2  | NS    | 324136 | 14         | MTO-306E4TP           | NS    | 064477 | 17         |
| 6   | 480   | 3     | 15                | 3         | 47-1/4      | MTO-306                         | NS    | 324144 | 11         | MTO-306E2  | NS    | 324152 | 14         | MTO-306E4TP           | NS    | 064485 | 17         |
| 7.5 | 240   | 3     | 15                | 3         | 57          | MTO-307                         | NS    | 324160 | 14         | MTO-307E2  | NS    | 324179 | 17         | MTO-307E4TP           | NS    | 064493 | 20         |
| 9   | 240   | 3     | 15                | 3         | 67-1/4      | MTO-309                         | NS    | 324187 | 15         | MTO-309E2  | NS    | 324195 | 18         | MTO-309E4TP           | NS    | 064506 | 21         |

Stock Status: S = stock NS = non-stock  
To Order—Specify model, volts, phase, kW, PCN and quantity.

1. Heaters with General Purpose Enclosures are UL Recognized and CSA Certified.
2. Heaters with Moisture Resistant/Explosion Resistant Enclosures are <sup>C</sup>CSA<sub>US</sub>® Certified.

**FASTShip**

Same-day shipping on stock item orders received before 4 pm CST.  
3-day shipping on assembly-stock items.