

Valves

Shear-Seal® Directional Control Valve

Series 9000, 9020

Features

- ▶ Original Shear-Seal® technology
- ▶ Interflow/non interflow
- ▶ Easy panel mounting
- ▶ Tolerates contaminants
- ▶ Spring return option

Applications

- ▶ Pilot valve for pneumatic valve actuators
- ▶ Gas manifold controls
- ▶ Manual control of 2-position cylinder



Shown with option "D" red ball type handle

General Specifications*

Working Pressure:	Pneumatic or hydraulic from 150 psi to 350 psi (10.3 to 24.1 bar); see table
Cv, Minimum Orifice:	See table
Back Pressure:	Must not exceed 250 psi (17.2 bar) at return port for satisfactory operation
Proof Pressure:	1-1/2 times working pressure except at return port (without damage to valve)
Burst Pressure:	2-1/2 times working pressure except at return port (300 psi, 20.7 bar)

Media Temperature Range:	-40° to +250°F (-40° to +121°C)
Wetted Material:	
Body:	Anodized aluminum
Standard O-Rings:	Buna N
Pressure Seals:	Brass
Rotor:	Hard anodized aluminum
Handle Rotation:	90°; 45° each side of center
Detent:	3-position detent (except -MC, -MR options)

* See product configurator for additional options.

Selector Valves

FLOW PATTERNS
(VIEWED FROM SHAFT END)

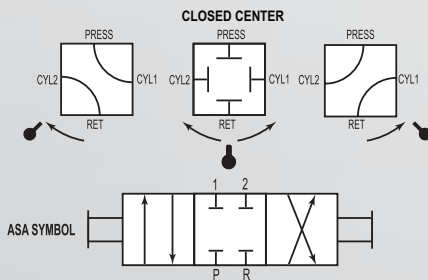

Manipulator Valves

FLOW PATTERNS
(VIEWED FROM SHAFT END)

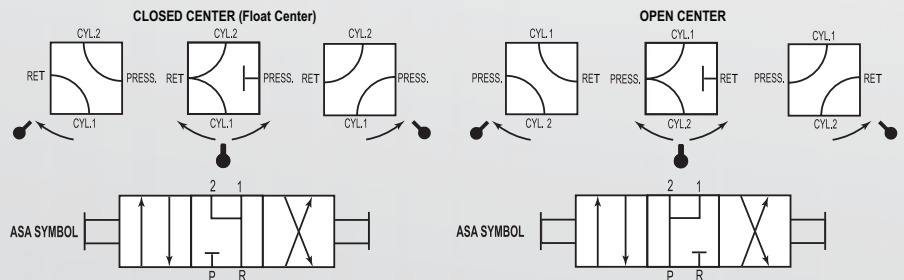

	Port Size NPT	Min. Flow Passage Dia.	Cv Factor	Air and Oil Rated Pressure psi (bar)	Manipulator Rated Pressure psi (bar)	Approx. Shipping Weight lbs. (kg)
9000 Series Non Interflow	1/4"	3/16"	0.52	150 (10.3)	150 (10.3)	2 (0.9)
	3/8"					
	1/2"					
9020 Series Interflow	1/4"	3/8"	2.3	350 (24.1)	250 (17.2)	2 (0.9)
	3/8"					
	1/2"					

Barksdale®
CONTROL PRODUCTS

CRANE Barksdale, Inc./Barksdale GmbH
A Subsidiary of Crane Co.

Shear-Seal® Directional Control Valve

Series 9000, 9020

Technical Drawings

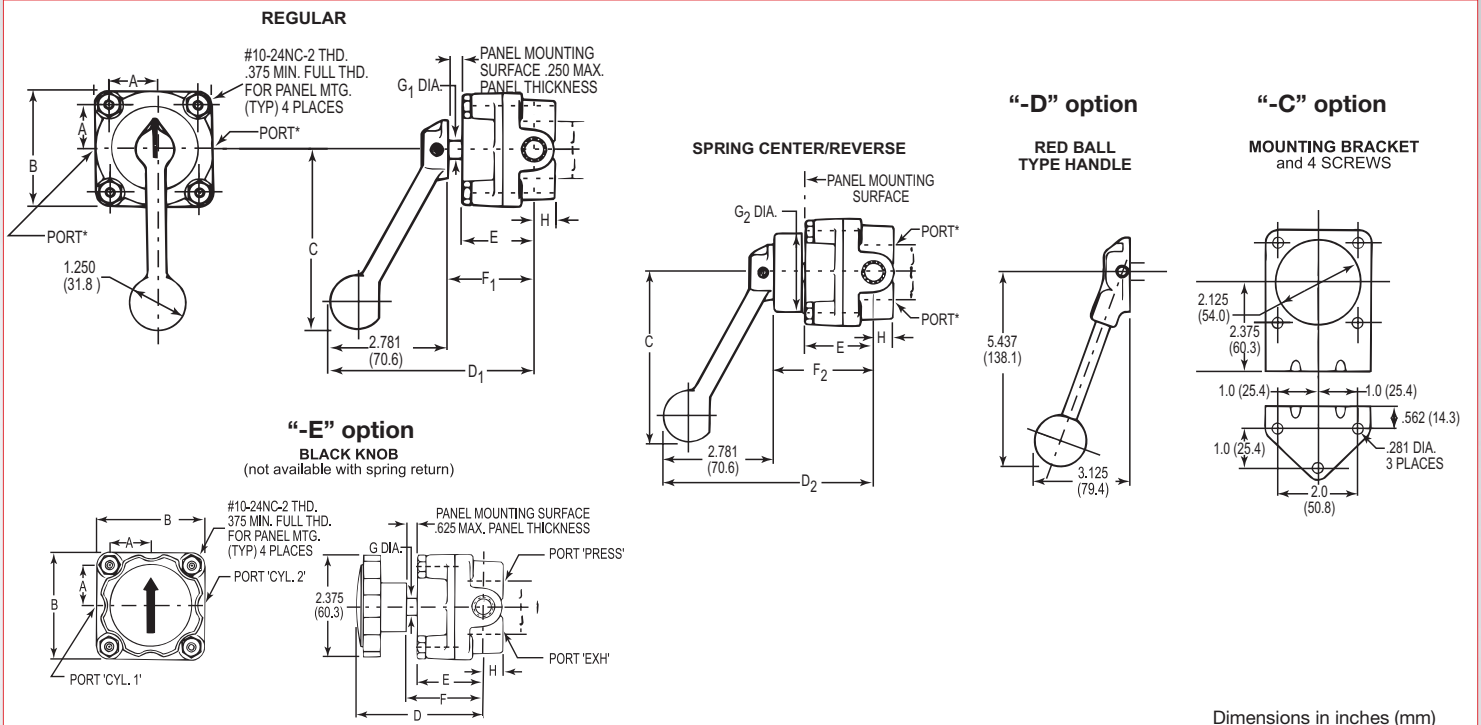

PORT SIZE NPT	A	B	C	Black Knob	Regular	Spring Center/Rever	E	Black Knob	Regular	Spring Center/Rever	Black Knob	Regular	Spring Center/Rever	H	J
	A	B	C	D	D-1	D-2	E	F	F-1	F-2	G	G-1	G-2	H	J
1/4 & 3/8	1.000 (25.4)	2.625 (66.7)	4.125 (104.8)	3.656 (92.9)	4.781 (121.4)	5.188 (133.8)	1.688 (42.9)	2.062 (52.4)	2.000 (50.8)	2.406 (61.1)	0.437 (11.1)	0.437 (11.1)	1.906 (48.4)	0.531 (13.5)	0.656 (16.7)
1/2	1.000 (25.4)	3.125 (79.4)	4.125 (104.8)	3.718 (94.4)	4.843 (123.0)	5.250 (133.4)	1.750 (44.5)	2.125 (54.0)	2.062 (52.4)	2.468 (62.7)	0.437 (11.1)	0.437 (11.1)	1.906 (48.4)	0.625 (15.9)	0.937 (23.8)

Product Configurator

Example: 902 2 -M

Series

900	Non interflow
902	Interflow

Port Size

1	1/4" pressure port
2	3/8" pressure port
3	1/2" pressure port

Operation

-M	Manual operation
-MC	Manual (spring return to center)
-MR	Manual (spring return to reverse)

Optional O-ring Material

-Z13 Viton seals

Options

-B	2-position 90° rotation (no center position)
-C	Mounting bracket w/ 4 screws
-D	Red ball type handle
-CD	Mounting bracket & red ball type handle
-E	Black knob (not available for spring return)

Flow Pattern

	Blank if closed center selector
-A	Closed center manipulator
-G	Open center manipulator